

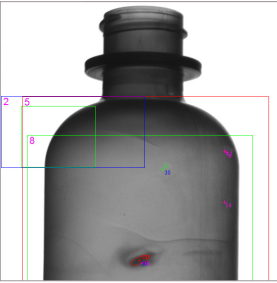

Distributed by  
**DARTRONICS, INC.**  
 PACKAGING AUTOMATION SPECIALISTS

# V57 System

## Modular Vision Inspection



### Sidewall Inspection

Check for contaminants, debris, cracks or improper formation on sidewalls to verify only top-quality containers advance on the production line.



### Verify Ovality Formation

Inspect proper plastic formation ovality or symmetry for packaging integrity in downstream packaging operations.

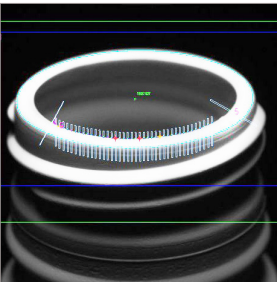

### Customized Applications

Perform other custom inspection requirements, such as neck threading, container formation or other package integrity inspections.



### Global Service Support

A global network of service experts provide fast remote and on-site support. Our comprehensive service offering allows you to achieve regulatory compliance, high performance, and maximum uptime throughout the life cycle of your product inspection equipment.



### Customizable, Precise Quality Control

Immediate contamination detection and precision formation inspections of rigid plastic containers.

- **Advanced Product Handling** – Product tracking, product handling options and intuitive software enable efficient visual inspection of every product.
- **Real Time Quality Control** – Installed directly after product formation, the system minimizes the chances that mis-formed or contaminated products continue to downstream processes.
- **Precise Package Presentation** – Detect product contamination as small as 0.1 TAPPI for top-quality product.

# V57 Modular Vision Inspection

## Technical Specifications

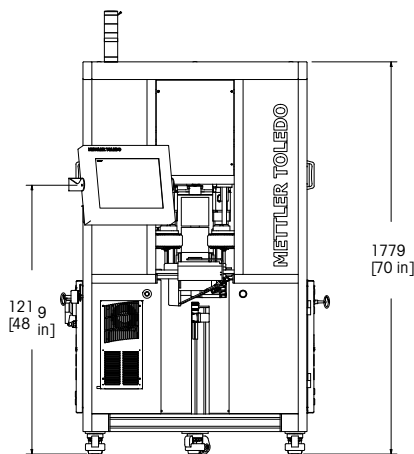

Sample schematic – Front and side view (example dimensions)

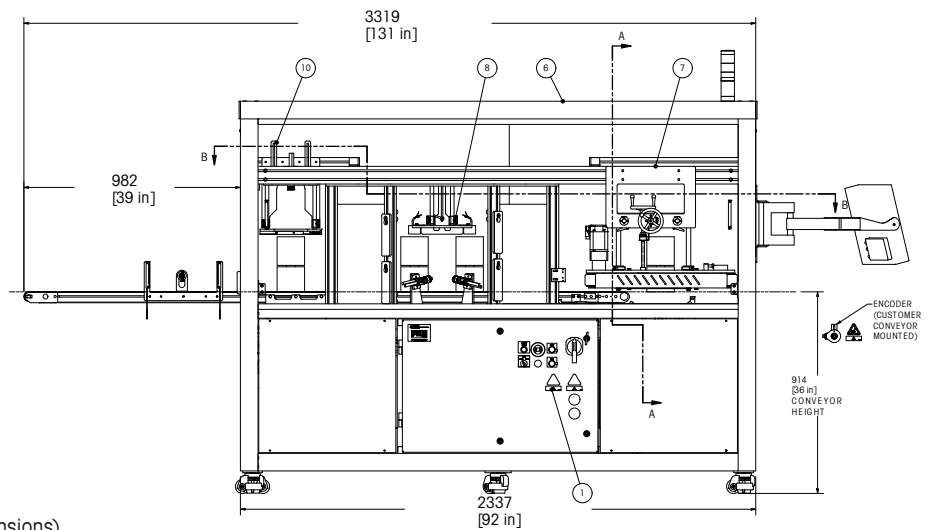

### Inspection Capabilities

- Shoulder/Thread Formation
- Sealing Surface Defects
- ID/OD/Ovality
- Thread Dimensions
- Surface Contamination
- Wall Thickness
- Gate Inspection

### Available Configurations

- **Multiple Lighting Options** – Our advanced lighting systems are designed to create optimal contrast to detect all defects on labeling and packaging.
- **Advanced Camera Configurations** – Powerful pc-controlled cameras come in a variety of resolutions, lenses, and filters and are designed for optimum speed and performance for your application.

### Typical Containers – Rigid Plastic Bottles

#### Applications

Inspection of plastic bottles for package integrity, contamination detection, neck thread quality and sealing surfaces.



Model	V57 Modular Vision System
Product Shape	Any rigid plastic
Inspection Area	Top; Front; Rear; Bottom
Product Width	Varies
Inspections	Ovality; Sealing Surface; Neck Threading; Labeling; Sidewall; Custom Applications
Cameras	Up to 14 PC-Controlled GigE Cameras
HMI	15" Color Touchscreen
Throughput	Up to 1,000 ppm
Design Options	Standalone
Power Requirements	110 - 230 V (single phase), 50 - 60 Hz
Operating Temperature (no A/C)	<35 °C(95 °F) <80 % humidity
Hygienic Requirement	Wipe Down (<IP54)

Note: The system has additional options that can be configured to your production line. Contact us to get a quote.

**METTLER TOLEDO Service** with global reach and tailored care solutions



### Dartronics, Inc.

150 William Street  
Perth Amboy, NJ 08861 USA  
Tel: (732) 324-0800  
Fax: (732) 324-4488  
Email: sales@dartronics.com

**For more information**

[www.dartronics.com/vision-inspection-solutions/](http://www.dartronics.com/vision-inspection-solutions/)



**DARTRONICS, INC.**

PACKAGING AUTOMATION SPECIALISTS

