



V15 Label Inspection 360° System

Compact. Efficient. Reliable.



Optional Top and Bottom Cameras

Enhance the functionality of the V15 with up to two additional smart cameras to perform top and bottom vision inspection on lids or container bottoms to verify Best Before Dates, LOT numbers or 1D/2D barcodes.



Label Data and Quality Control

Delivers full inspection of label data such as 1D/2D barcodes and alpha-numeric codes for errors. Quality defects such as label positioning, multi-labeling, skews, wrinkles, folds, print quality and the graphic ID are also verified for conformity.



Available as a Combination System

Integrate the V15 with our other inspection technologies such as checkweighing or metal detection, or both, into a single, space-saving device. Shared material handling, sorting and reject mechanisms aid productivity and reduce cost.



Global Service Support

Our global service network provides reliable support and professional installation for enhanced performance. Rapid delivery of spare parts reduces downtime.



V15 Label Inspection 360° System

This space-saving solution detects label data and quality defects on round products. Six image sensors are enclosed in a compact design that can easily be installed over existing conveyors. The V15 can be extended with top and bottom cameras.

- **100% Automated Label Inspection 360°** – This cost effective vision system is ideally suited to replace manual spot checks with 100% automated label inspection control for round products.
- **Compliance Support** – Supports consumer safety in offering documented label inspection in line with industry guidelines such as IFS and BRCGS.
- **Reduce Waste and Prevent Recalls** – Verifies labels to detect and reliably reject non-conforming products to avoid costly recalls due to false or missing declarations.

V15 Label Inspection 360° System

Technical Specifications

Applications

- Label data and quality inspection on round packages, bottles, jars and tubs

Increase Productivity

- Product changeover is quick and easy thanks to the liquid lens technology and height adjustment capabilities

Compact Design for Wet Environments

- Space saving design with sloped surfaces throughout for easy cleaning
- IP65-rated stainless steel construction is ideally suited for wet environments across food, beverage and cosmetics industries

Software Capabilities

- User friendly operator software simplifies the set-up of products and supports product changes to be managed centrally
- Embedded user management provides security. Based on the established checkweighing software for minimal operator training requirements
- Fieldbus and OPC technologies enable IoT / Industry 4.0 initiatives to access, analyze and control production data anytime and anywhere
- The system can be connected to the ProdX™ quality management software

Available as a Combination System

- Integrate with our checkweighing, metal detection or x-ray inspection technologies into a single space saving device
- Shared material handling, sorting and reject mechanisms improve productivity and reduce cost

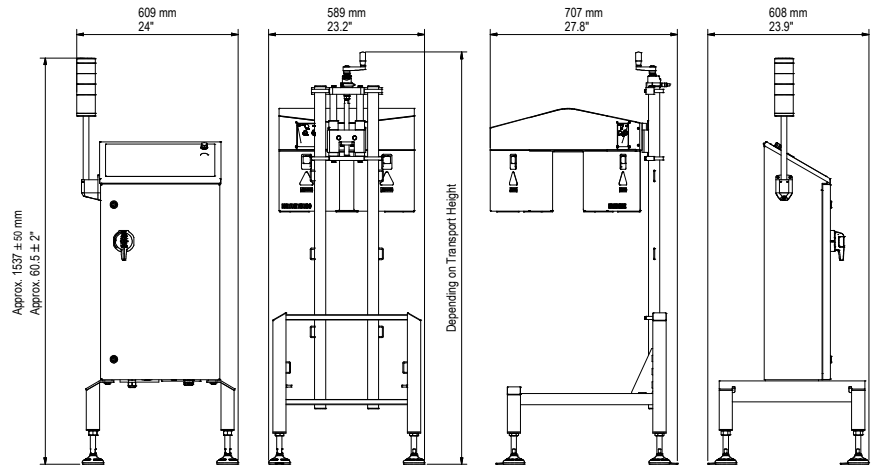

Standard Schematic with Frame and HMI separated – V15 Round Line front view and perspective side view (typical dimensions in mm). Additional configurations available.

Model	V15 Label Inspection 360° System
Product Shape	Round
Max. product diameter in mm	100
Max. inspection height (in mm)	Codes should be no lower than 230 mm from the top of the package
Field of View	110 x 83 mm; 120 x 90 mm
Inspection Area	360° Side; Optional Top and Bottom
Inspection field (volume) height in mm	110, beginning 8 mm below system's bottom edge
Label Data Inspection	1D/2D Barcodes, Alpha Numeric
Label Quality Inspection	Label Wrinkles; Graphical ID; Label Placement; Label Skew
Cap Inspection	Presence, Color, Skew
Throughput	Up to 500 ppm
HMI	12" Colour Touchscreen
Design Option	Kit; Standalone; Checkweigher Integration
Cleaning Requirement	Wipe Down (IP54); Low Pressure (IP65)
Number of Cameras	Up to 3 Smart Cameras
Vision Combinations	Contamination Detection; Dynamic Checkweighing
Line Height	750 to 1050 mm

Note: The system has additional options that can be configured to your production line. Contact us to get a quote.



Dartronics, Inc.

150 William Street
Perth Amboy, NJ 08861 USA
Tel: (732) 324-0800
Fax: (732) 324-4488
Email: sales@dartronics.com

For more information

www.dartronics.com/vision-inspection-solutions/



DARTRONICS, INC.
PACKAGING AUTOMATION SPECIALISTS