

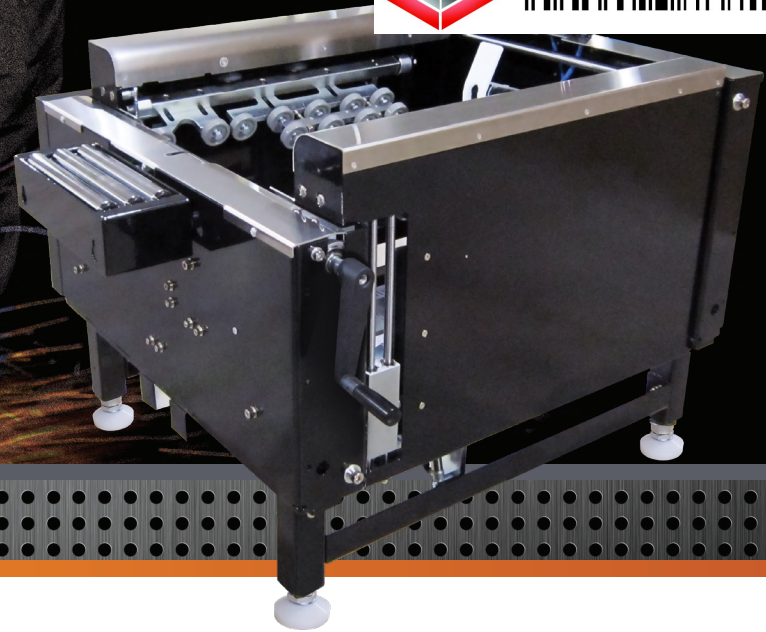

Distributed by
DARTRONICS, INC.
PACKAGING AUTOMATION SPECIALISTS



 **First in Quality. Built to Last.**



EX-CF

CASE FORMER

CASE FORMING MADE EASY

The EX-CF Case Former from Easteey is designed for semi-automatic case forming and packing. The durable design has proven to keep production and maintenance efforts to a minimum to improve your case packing process. The EX-CF Case Former provides a fast and cost-efficient alternative to manual case forming.

EASY OPERATION

The EX-CF Case Former enables a single operator to form, pack, and seal corrugate cases. Operation is simple: open the case and place it in the top of the case former. Pneumatic switches activate the machine's flap folding mechanism to fold the bottom major and minor flaps. Once the flaps are folded, the case will stay in place while the case is filled by the operator. Filled cases can then be advanced into a taper for automated top and bottom case-sealing.

INCREASED PRODUCTIVITY

EX-CF Case Former offers fast and easy case size changes with adjustable hand-crank side rails to accommodate boxes 8" to 25.5" in length, 6" to 19" wide, and 3.5" tall and greater.

COMPACT CASE FORMING AND PACKAGING

Designed for semi-automatic case forming and packing, the EX-CF will improve productivity and increase your ROI

INDUSTRIAL QUALITY

Each EX-CF machine is made from sturdy 12 gauge steel, high quality construction, and a powder coated exterior to protect the machine from abusive conditions for guaranteed years of use. The EX-CF will be a workhorse in your industrial case packing operation.

INCREASE YOUR ROI

The use of Easteey's EX-CF case forming machine can be learned in minutes, avoiding breaks in production and downtime. For increased efficiency, EX-CF Case Former can be combined with any Easteey Case Taper for automated case sealing.

THE RIGHT SOLUTION

Rugged design. Proven reliability. Simple operation. Your benefits go on and on. When it comes to industrial operation, rely on Easteey to provide the right solution for your case sealing needs.



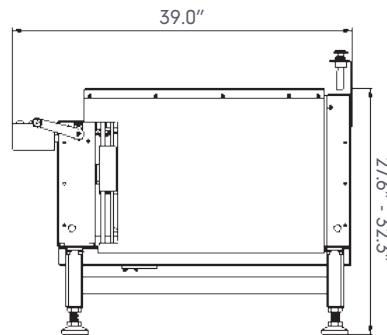
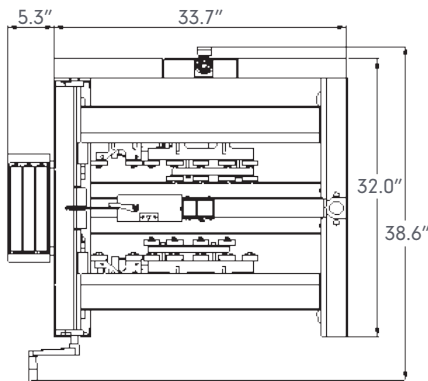
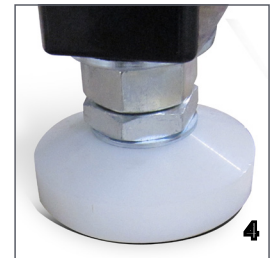
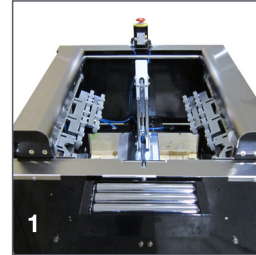

1. Stainless steel wear surfaces
2. Easy case size changes with adjustable folding/revolving crank handle
3. Air only operation with emergency stop
4. Adjustable foot extensions for level setup, or optional caster for movement within your plant

EX-CF FEATURES	EX-CF SPECIFICATIONS			
<ul style="list-style-type: none"> Plug-in and go operation Adjustable side guides Adjustable foot extensions Fast and easy box size changes Low maintenance Accommodates wide case range Roller extension included for wide boxes Small exit roller table included 	Machinery Makeup	Industrial strength 12 gauge steel, powder coated for durability		
	Conveyor Height Adj.	23.75" (603mm) to 29.75" (756mm) with leveling legs; 27.25" (692mm) to 33.25" (845mm) with optional casters		
	BOX SPECIFICATIONS	Length	Width	Depth
	Minimum Box Size	8" (203.2mm)	6" (152.4mm)	3.5" (88.9mm)
	Maximum Box Size	25.5" (647.7mm)	19" (482.6mm)	Unlimited
	Air Requirements	80 PSI		
	Electrical Requirements	None		
	Agency Approvals	CE Certification		



DARTRONICS, INC.
 PACKAGING AUTOMATION SPECIALISTS

150 Williams Street, Perth Amboy, NJ 08861
 Phone: (732) 324-0800
 Fax: (732) 324-4488
 Email: sales@dartronics.com