

DARTRONICS, INC.

PACKAGING AUTOMATION SPECIALISTS

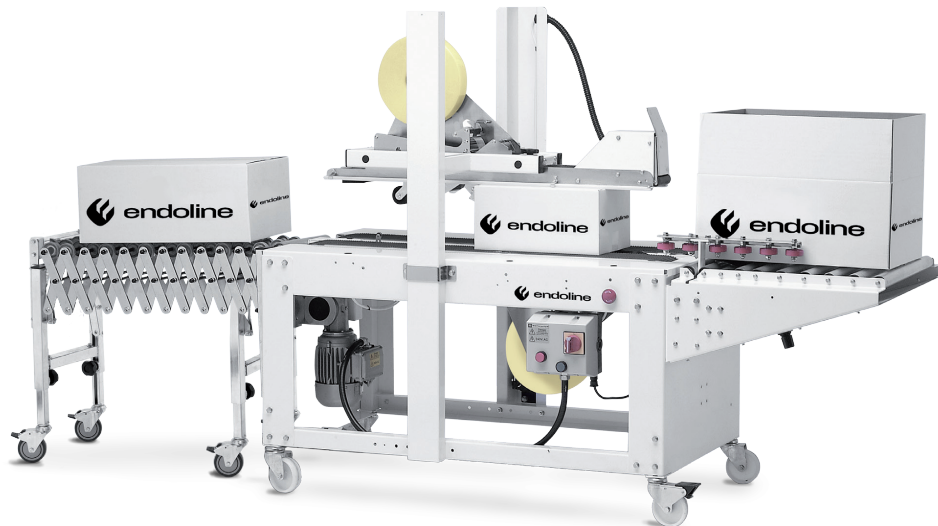

714

Semi-Automatic Random Case Taper



Random Case Sealing

The Endline 714 will automatically adjust its settings to seal 0201 cases top and bottom throughout the case size range in any random sequence. The 714 can operate on small, large, lightweight or heavy cases and can be integrated with a case former to assist with forming the bottom case flaps to increase packing speeds.



Ease of Operation

Simple mechanical operation and clear access for easy cleaning and maintenance make this an efficient and straightforward machine to operate. Fitted as standard with a steel roller infeed table and brake castors.



Twin Column Construction

The use of our unique twin column design provides added stability for the taping bridge to ensure the machine runs smoothly at all times with minimal interruption and it provides the support necessary for the floating bridge feature.



Robust Construction

High quality components housed in a robust chassis ensure minimal servicing and enable 24 hour operation. The 714 is designed for the rigours of typical end-of-line packaging environments.



Interchangeable Tape Heads

The 714 uses any machine tape up to 50mm wide, 1000m long and features instantly removable, interchangeable tape heads, easily threaded, with integral knife guards.



Compact

The Endline 714 is well suited to environments where there is insufficient space for multiple sealers or there are regular case size changes.





714

Semi-Automatic
Random Case Taper

Options include:

- High Speed system for increased speeds
- Sealing cases down to 50mm high possible with guarding
- Low tape and no tape sensing
- Visual/audible alarm
- Discharge blocked sensing Endline

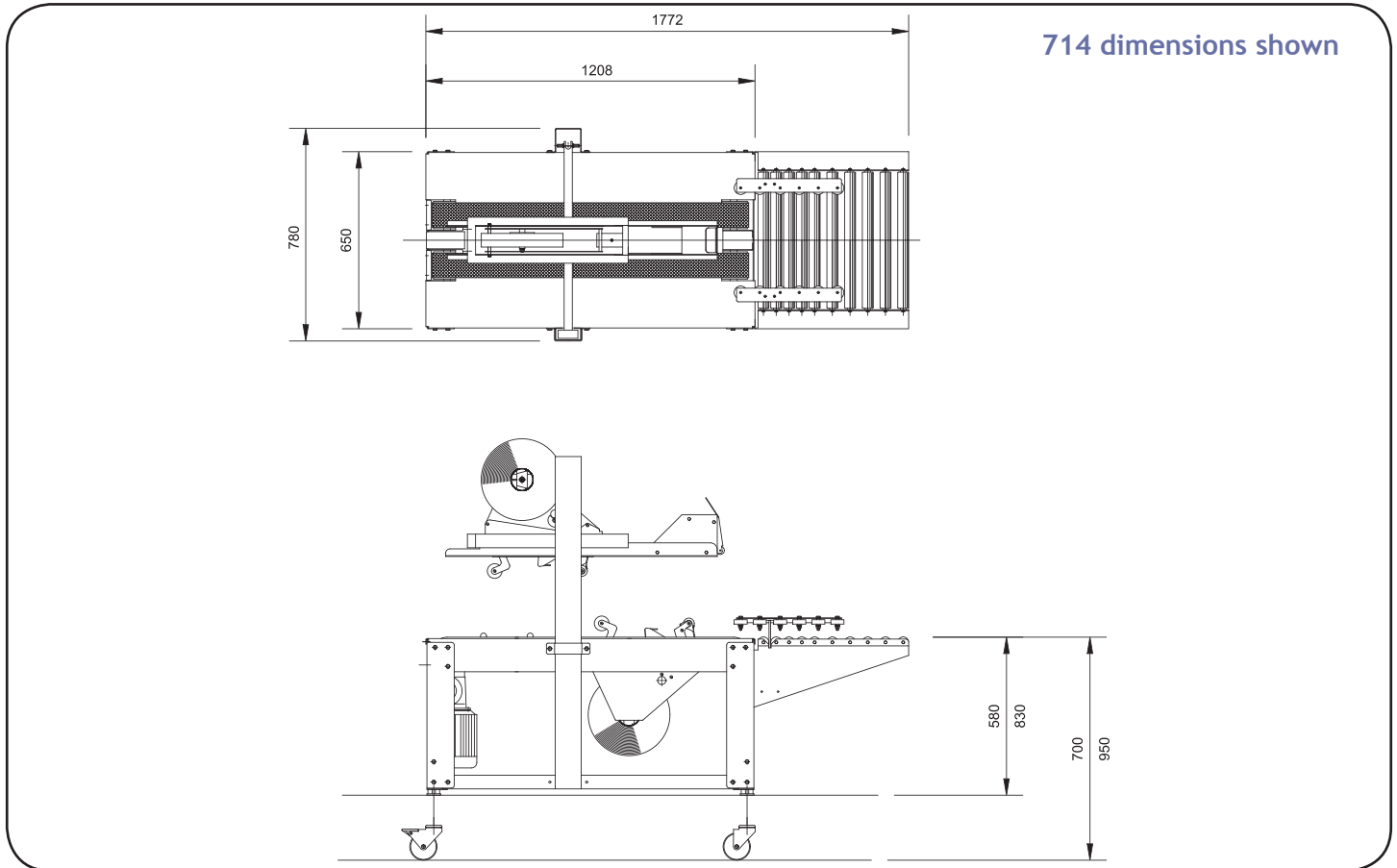

Case Dimensions (mm).

	Length	Width	Height
Minimum	185	140	110
Maximum	inf	460	520

Note:

- Machine can be modified for cases outside case size range. Please contact Endoline to advise.

Electrical Supply

- Single phase: 240V, 50Hz
- Three phase: 415V, 50Hz

Pneumatics

- 80psi (5.5 bar)

Machine Finish

- Mild steel, powder coated white
- (RAL9010) or stainless steel

Tape Size

- Standard: up to 50mm wide
- Optional: up to 75mm wide

Dartronics, Inc.

150 William Street, Perth Amboy NJ 08861

Phone: 732.324.0800 Fax: 732.324.4488 Toll Free: 1.800.298.8936 E-mail: sales@dartronics.com

