**DARTRONICS, INC.**

PACKAGING AUTOMATION SPECIALISTS



# 702

## Fully Automatic Pre-Set Case Taper



### High Speed System

Offers secure, accurate taping at up to 25 cases per minute, with no operator required.



### Ease of Operation

The 702 is easy to install with height adjustment and castors. It has simple mechanical operation and clear access for easy cleaning and maintenance.



### Four Column Construction

The use of our unique four column design provides added stability for the taping bridge to ensure the machine runs smoothly at all times with minimal interruption. This fully automatic machine is fitted with two pairs of columns for additional support to the folding section.



### Robust Construction

High quality components housed in a robust chassis ensure minimal servicing and enable 24 hour operation. All our case tapers are designed for the rigours of typical end-of-line packaging environments.



### Interchangeable Tape Heads

The 702 uses any machine tape up to 50mm wide, 1000m long and features instantly removable, interchangeable tapeheads, easily threaded, with integral knife guards.



### Low Cost of Ownership

The Endline 702 is designed to give you the best possible value for your investment through maximum productivity with minimal stoppage time for problem-solving or case size changes.



# Pre-set Case Sealers



## 702

Fully Automatic  
Pre-Set Case Taper

### Options include:

- Low tape and no tape sensing
- Visual/audible alarm
- Discharge blocked sensing
- Infeed Spacing Table

702 dimensions shown

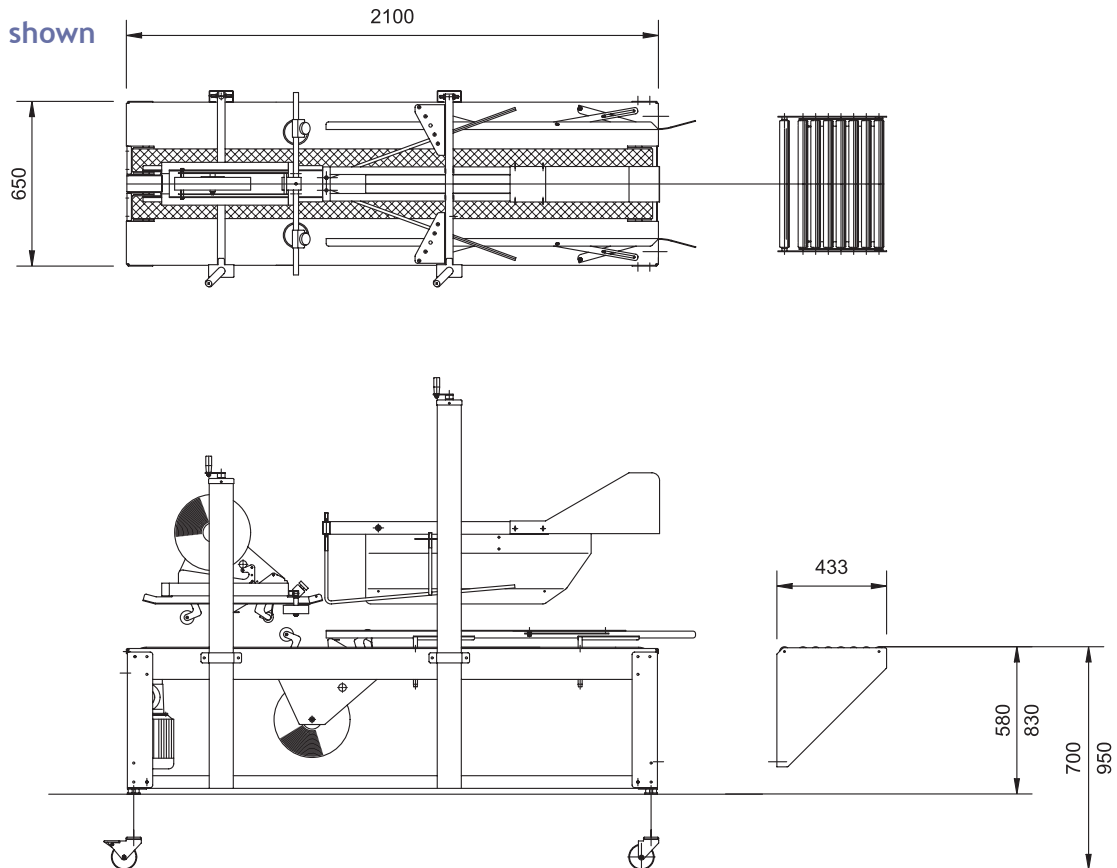

### Case Dimensions (mm).

	Length	Width	Height
Minimum	150	130	110
Maximum	600	490	510

### Note:

- Speeds up to 25 cases per minute subject to case size.
- Machine can be modified for cases outside case size range. Please contact Endoline to advise.

### Electrical Supply

- Single phase: 240V, 50Hz, 0.37kW
- Three phase: 415V, 50Hz, 0.37kW

### Pneumatics

- 80psi (5.5 bar)

### Machine Finish

- Mild steel, powder coated white (RAL9010) or stainless steel

### Tape Size

- Standard: up to 50mm wide
- Optional: up to 75mm wide

© Endoline reserves the right to change specifications without prior notice.

## Dartronics, Inc.

150 William Street, Perth Amboy NJ 08861

Phone: 732.324.0800 Fax: 732.324.4488 Toll Free: 1.800.298.8936 E-mail: sales@dartronics.com

