



DARTRONICS, INC.

PACKAGING AUTOMATION SPECIALISTS



(Flexi Conveyor shown is optional)

610

Semi-Automatic Pre-Set Case Taper



Floating Bridge

The floating bridge allows the machine to accept swollen or out-of-specification cases while providing consistent and accurate sealing. A bridge-latch enables quick and easy access to the bottom tapehead for quick tape reload without re-adjustment.



Interchangeable Tapeheads

The instantly removable, interchangeable tapeheads are easily loaded and are fitted with integral steel knife guards. This means that fewer spare tapeheads are required thereby significantly reducing spare parts costs. Rapid tape reload (top and bottom) can be achieved just by swapping tapeheads.



Twin Column Construction

The use of our unique twin column design provides added stability for the taping bridge to ensure the machine runs smoothly at all times with minimal interruption and it provides the support necessary for the floating bridge feature.



Efficient

This machine is designed for quick and easy manual size change and a tool-free changeover for each case size and can be run by a single operator with automatic taping to improve case packing efficiency.



Compact

Our machines have a compact footprint and will not take up a great deal of space in your production area. They are fully portable with adjustable legs with height scales for easy installation.



Low Cost Of Ownership

All Endoline's machines are designed for maximum efficiency and productivity thereby reducing the cost of ownership to a minimum. This case sealer come sat a low capital cost and immediate savings can be seen through reduced labour costs and increased packing speeds.



Pre-set Case Sealers



610

Semi-Automatic
Pre-Set Case Taper

Options include:

- Case clamps
- Discharge conveyor
- Top brush
- Spares kit

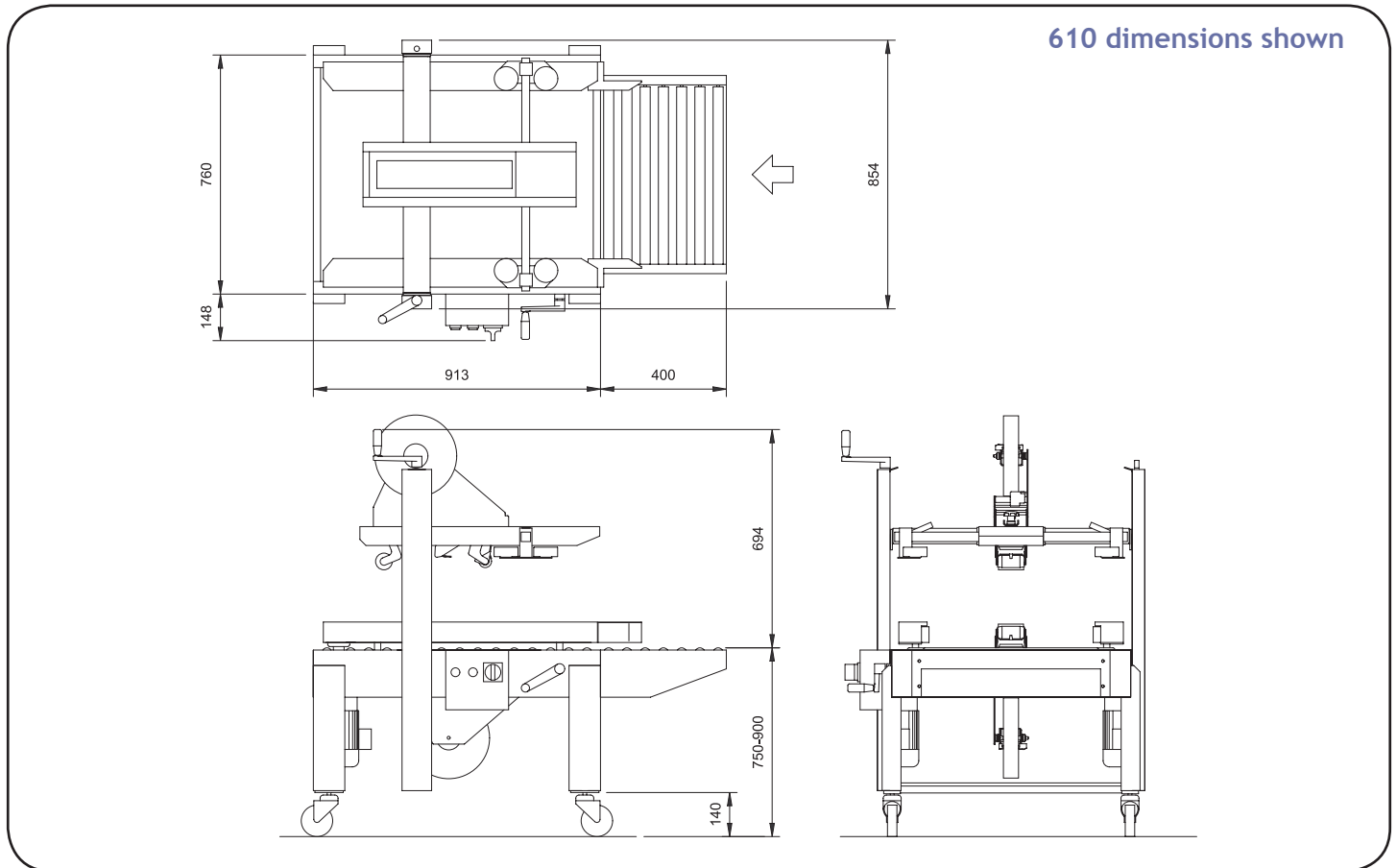

Case Dimensions (mm).

Length	Width	Height
120 to inf	100 to 500	110 to 500

Electrical Supply

- 240V/1ph/50Hz
- 500W
- 2 amps nominal

Machine Finish

- Mild steel painted RAL9010

Tape Size

- Standard: up to 50mm wide

Bed Height

- With castors 600 - 820mm

Handing

- Right to left
- Left to right

Controls

- Stop/Start and Remote
Emergency Stop

© Endoline reserves the right to change specifications without prior notice.

Dartronics, Inc.

150 William Street, Perth Amboy NJ 08861

Phone: 732.324.0800 Fax: 732.324.4488 Toll Free: 1.800.298.8936 E-mail: sales@dartronics.com

