



DARTRONICS, INC.

PACKAGING AUTOMATION SPECIALISTS



242-244

Fully Automatic Case Erectors



Servo Drives

While allowing the machine to reach higher speeds - up to 18 cases per minute - the servo drive system permits greater flexibility and control by allowing almost instant acceleration and deceleration of cases through the erecting process. In turn this system can save energy because the servo drives only use power when needed.



Easy to Use

The 240 series is designed with clear access, simple controls and quick to adjust size changes. The machines are operator friendly and allow for quick and easy size change, cleaning maintenance to ensure minimal machine down time.



High Speed

The 242/244 range is fitted with servo drives to further increase the number of cases sealed per minute up to 18 cases per minute.



Compact

With a surprisingly compact footprint this machine will fit into areas with restricted floor space or areas not normally suited to the installation of large or bulky machinery.



Dual Opposing Vacuum Case Opening

This unique design feature ensures that each case is opened positively from both sides. It ensures the efficient and reliable opening of cases, and overcomes problems that can be associated with stiff board and glue migration from the manufacturer's joint.



Robust Construction

High quality components housed in a robust chassis ensure minimal servicing and enable 24 hour operation. These systems are designed for the rigours of typical end-of-line packaging environments.



Case Erectors



242 & 244

Fully Automatic
Case Erectors

Options include:

- Extended hopper magazine
- Low hopper sensing
- Low tape/glue and no tape sensing
- Visual/audible failure alarm
- High speed

242 dimensions shown

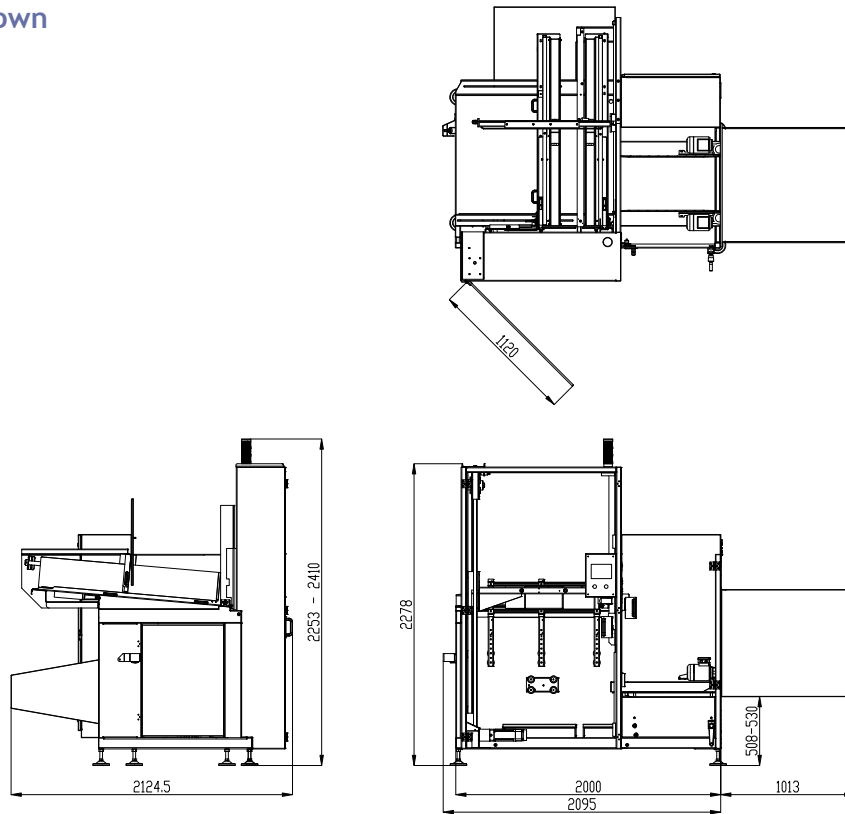

Note:

- The 242 case erector seals cases with self-adhesive tape.
- The 244 case erector seals case with hot melt glue.
- Case speed is subject to case size.
- Machine can be modified for cases outside case range. Please contact Endline to advise.

Case Dimensions (mm).

	Length	Width	Height (Open)
242/244 Minimum	200	200	175
Maximum	600	500	600

Speed

- Standard up to 18 cases per minute

Machine Finish

- Mild steel, powder coated white (RAL9010) or stainless steel

Electrical Supply

- Type 242 Three Phase: 400V, 50Hz, 20A/phase
- Type 244 Three Phase: 400V, 50Hz, 28A/phase

Tape Size

- Standard: up to 50mm wide
- Optional: up to 75mm wide

Pneumatics

- Type 242: 30 litres per cycle at 5.5 bar
- Type 244: 24.5 litres per cycle at 5.5 bar

© Endline reserves the right to change specifications without prior notice.



Distributed by

DARTRONICS, INC.

PACKAGING AUTOMATION SPECIALISTS



Dartronics, Inc.

150 William Street, Perth Amboy NJ 08861

Phone: 732.324.0800 Fax: 732.324.4488 Toll Free: 1.800.298.8936 E-mail: sales@dartronics.com

