



# 251 / 253

## Fully-Automatic Case Erector



### Dual Opposing Vacuum Case Opening

This unique design feature ensures that each case is opened positively from both sides. It ensures the efficient and reliable opening of cases, and overcomes problems that can be associated with stiff board and glue migration from the manufacturer's joint.



### Low Cost of Ownership

The Endline 250 Series of Case Erectors is designed to give you the best possible value for your investment through maximum productivity with minimal stoppage time for problem-solving or case size changes.



### Robust Construction

High quality components, housed in a robust, computer designed chassis allow for minimal servicing. Designed for the rigours of typical end-of-line packaging environments.



### Compact

With a surprisingly compact footprint these machines will fit in to areas with restricted floor space or areas not normally suited to the installation of large or bulky machinery.



### Easy to Use

The 250 Series is designed with clear access, simple controls and quick to adjust to size changes. The machines are operator friendly and allow for quick and easy size change, cleaning and maintenance to ensure minimal machine down time.



### Extended Warranty

Two year fully comprehensive warranty for peace of mind and reduced cost of ownership.





## 251/253

Fully-Automatic  
Case Erector

### Options include:

- Low hopper sensing.
- Low tape and no tape sensing.
- Visual/audible failure alarm.
- Low glue sensing (253).

### 251 dimensions shown

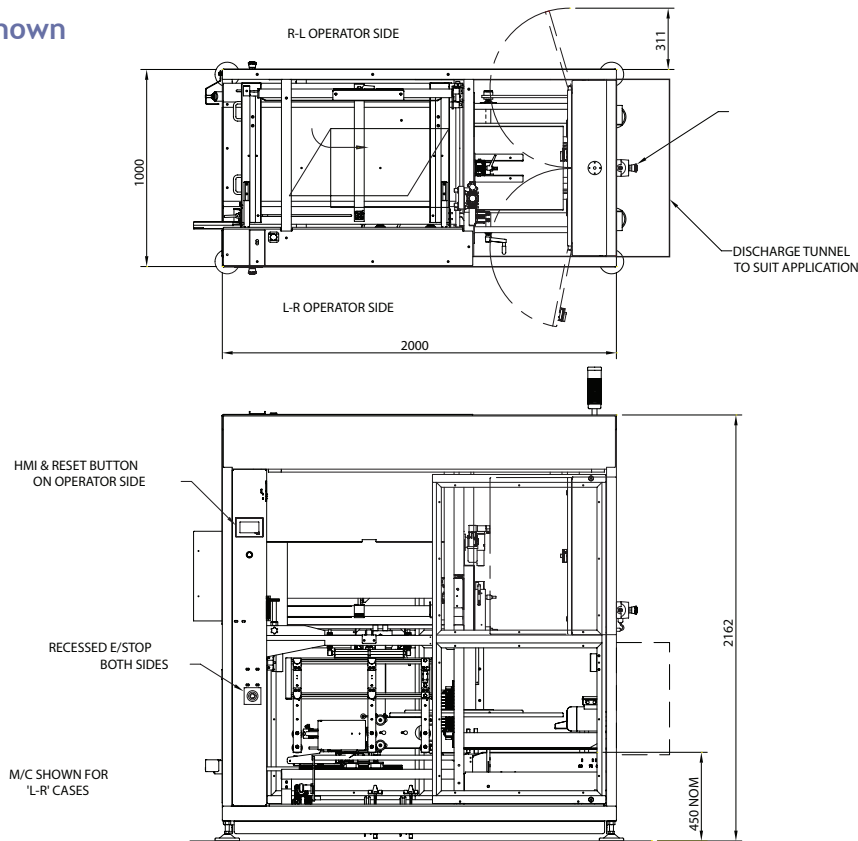

### Note:

- The 251 case erector seals cases with self-adhesive tape.
- The 253 case erector seals cases with hot melt glue.
- Case speeds subject to case size.
- Machine can be modified for cases outside case size range. Please contact Endoline to advise.

### Case Dimensions (mm).

	Length	Width	Height
251/253 Minimum	300	200	200
Maximum	650	400	500

### Electrical Supply

- Type 251 Three phase: 3/ 380-415 V 50Hz
- Type 253 Three phase: 24/ 208 V 60Hz

### Machine Finish

- Mild steel, painted RAL 9010
- Stainless Steel 304 construction.

### Pneumatics

- Type 251 SMC 5.5 bar, 370 L/min
- Type 253 SMC 5.5 bar, 510 L/min

### Speed

- 10 cases per minute

### Tape Size

- Standard: up to 50mm



Distributed by  
**DARTRONICS, INC.**

PACKAGING AUTOMATION SPECIALISTS



150 William Street Perth Amboy, NJ 08861  
Phone: 732.324.0800 Fax: 732.324.4488 Toll Free: 1.800.298.8936 E-mail: sales@dartronics.com

