

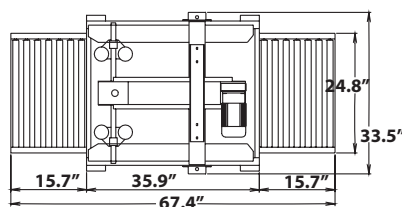

1. Designed for over-sized, heavyweight cases that are too large for most case sealing equipment
2. Four belts work in unison to efficiently move cases through the taper for a strong and consistent seal
3. Easy-to-use hand crank allows for quick product height adjustments
4. Top and bottom tape heads are identical and can be removed without tools

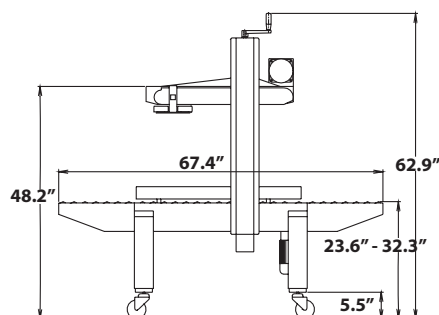

SB/TB-2 FEATURES

- Plug-in and go operation
- Fast and easy box size changes
- Industrial strength side belts
- Interchangeable top and bottom tape cartridges
- Emergency stop button
- Adjustable leg extensions
- Casters included for transportation within plant
- Front and rear pack tables included to allow for case packing
- Top squeezers push top flaps together on overfilled case
- Powder coated 12 gauge steel
- Low maintenance, no air required

SB/TB-2 TAPING SPECIFICATIONS

Sealer Type	Side and top belt case sealer
Machinery Makeup	Industrial strength 12 gauge steel, powdered coated for durability
Belt Speed	75 fpm
Tape Speed	30 cases per min., depending on box size and operator efficiency
Height Adjustment	Standard adjustable legs for 23.6" to 32.3" conveyor heights

BOX SPECIFICATIONS		Length	Width	Depth
Minimum Box Size		4.5"	6.0"	4.0"
Maximum Box Size		Infinite	27.5"	27.5"
Tape Size	2" wide pressure sensitive tape, up to 15" diameter rolls, optional 3" wide tape			
Tape Cartridge	Proven design requires no lubrication, designed for simple tape threading, removable for maintenance and interchangeable with top or bottom cartridges			
Drive Motor	Three (3) 1/4 HP drive motors			
Electrical Requirements	110 VAC, 60Hz, 4.0A			
Agency Approvals	CE Certification			

SB/TB-2 OPTIONAL ACCESSORIES

3" Tape Head	Accepts 3" wide tape rolls
--------------	----------------------------



150 William Street, Perth Amboy, NJ
 08861 Tel: 732.324.0800 Fax: 732.324.4488
 Email: sales@dartronics.com
 Web: www.dartronics.com

