

RCL-4x/RCL-6x

Robotic Carton Loader

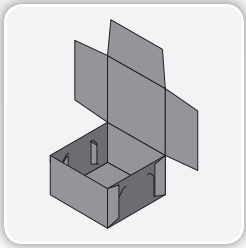

where products meet packaging®

Designed for maximum flexibility, performance and reliability, the ADCO RCL -4x (4-axis) and RCL-6x (6-axis) robotic carton loaders are ideal for the most demanding production environments. The RCL family of robotic carton loaders feature end-of-arm tool designs that are based on ADCO's decades of complex product handling and carton loading experience and can be configured to handle many types of products at rates up to 700 products per minute. Available in single or multiple robot configurations, ADCO's RCL carton loaders provide packagers with unparalleled speed, adaptability and investment protection. The RCL-4x and the RCL-6x feature stainless steel construction and are available in both standard and food grade configurations.

Benefits

- Stainless steel construction improves cleanability and eliminates corrosion
- Precision robotic motion ensures gentle product handling and quality output
- Unique FANUC parallel-link design maximizes speed and acceleration.
- Higher speed and acceleration reduces number of robots needed for an application, condensing overall footprint
- Six-axis design (RCL-6x) enables product feeding from the sides of a work zone, increasing the usable workspace.
- Fast, easy tool change reduces downtime and improves productivity

RCL-4x/RCL-6x - Robotic Carton Loader

Product Features

- Capable of speeds up to 700 products per minute, depending on the application
- Sanitary design with easy access for changeover and cleanup
- Infeed options including flat belt and servo-driven racetrack designs are available
- Random product infeed with optional integrated irVision
- Able to simultaneously load multiple cartons or trays
- Category 3 safety system with fully interlocked barrier guard package
- Many options available upon request

Typical Applications

- Snack foods
- Baked goods in trays
- Flow-wrapped products
- Frozen meats
- Dairy
- Personal care
- Cosmetics

Utilities

Electrical

200-230 VAC, 3-Phase with ground (PE), 50-60 Hz

Air Consumption

Consult Factory

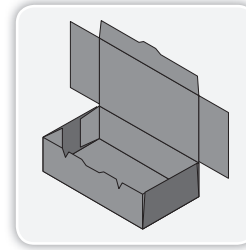
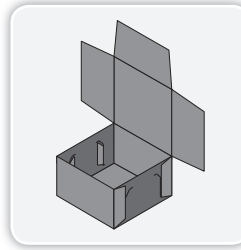

PLAN VIEW

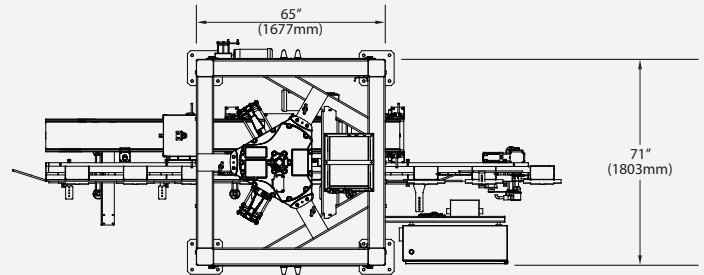

SIDE ELEVATION

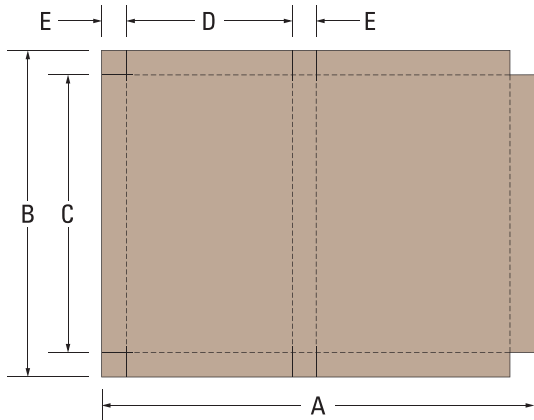
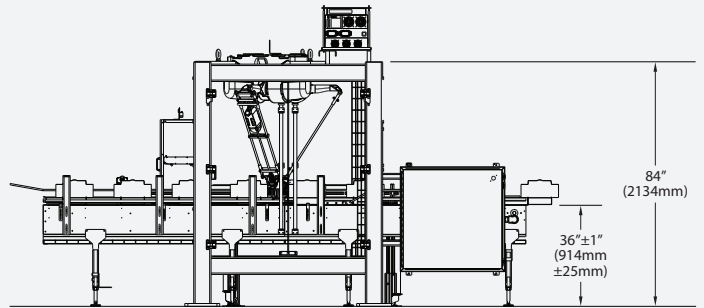

CARTON SIZE RANGE

Dimensions	(in)		(mm)	
	Min	Max	Min	Max
A	7.5	23	190	585
B	5	26	130	660
C	3	17	75	430
D	3	8	75	200
E	.75	4.5	19	115

Not all minimums and maximums apply.
Special modifications are available to extend the size range.

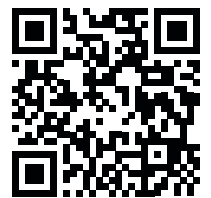

For more information about this machine, scan the QR code above with your mobile device