



Distributed by  
**DARTRONICS, INC.**  
 PACKAGING AUTOMATION SPECIALISTS

**EoL**  
 END OF  
 LINE

## M1000 SIDE LOAD CASE PACKER



### Precision case packing for low speed applications

The M1000 provides customers with a flexible alternative to upgrade their manual, low speed, hand pack operations. Accommodating RSC cases, the M1000 automatically performs multiple packaging operations including case erecting, loading and sealing sections within a compact footprint.

Designed to occupy similar floor space to hand pack operations, this machine runs with the same flexibility and durability as our high-speed machine and adapts to the packaging line speed. This solution is ideal for contract packers as well as food, beverage, pharmaceutical and personal goods industries due to its superior handling of bagged and sleeved products.

#### FEATURES AND BENEFITS

- Compact footprint, designed to occupy similar floor space to hand pack operations
- Fully automatic machine runs unattended reducing labor costs
- Uncluttered design for ease of machine accessibility
- Slide-Out tape heads for quick changeover
- Simple Automation
- Allen Bradley Controls Platform

## TYPICAL PRODUCT SPECIFICATIONS

<b>Footprint</b>	12' x 10'
<b>Speed</b>	Up to 10 cases per minute (product and pack pattern dependent)
<b>Product Type</b>	Bottles, cartons, bags, and sleeves
<b>Case Type</b>	Knock-down RSC end load
<b>Minimum Case Size</b>	10 x 20 x 6 inches (no set range predetermined, systems accommodate wide range of sizes)
<b>Maximum Case Size</b>	24 x 24 x 18 inches (no set range predetermined, systems accommodate wide range of sizes)

<b>Case Sealing</b>	Tape
<b>Display</b>	8.4" color, touchscreen Display
<b>Magazine Capacity</b>	150 Blanks (extended magazine available)
<b>Frame</b>	Continuous welded frame, Gray Powder Coat (stainless steel or washdown design available)
<b>Electrical Requirements</b>	NEMA 12 (NEMA 4 or 4X electrics available)
<b>Air Requirements</b>	80 PSI @ 16 cfm

## PRODUCT OPERATION

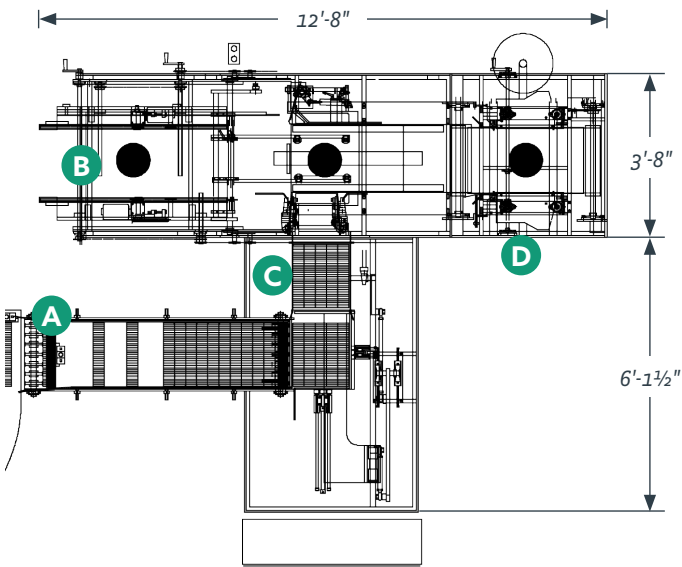

**DARTRONICS, INC.**

PACKAGING AUTOMATION SPECIALISTS



150 William Street Perth Amboy, NJ 08861

1-800-298-8936

Phone: 732-324-0800

Fax: 732-324-4488

Email: sales@dartronics.com

www.dartronics.com



### A. PRODUCT INFEEED

Flexible package conveys onto staging conveyor or racetrack (optional) to build appropriate pack patterns



### B. MAGAZINE

A single case blank is picked from the magazine and the case is set into the loading station.

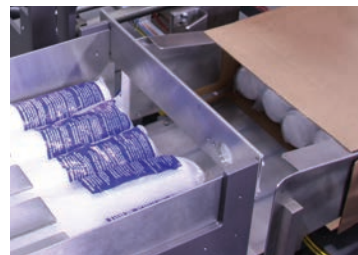

### C. CASE LOAD

The major flaps are contained so the case remains in the loading section and the loading funnels open the minor flaps and the case is loaded.

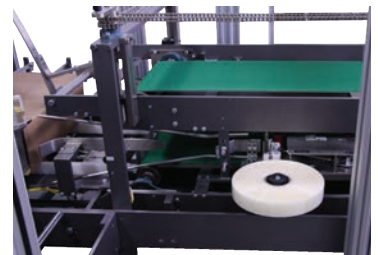

### D. CASE SEAL

After loading, the full case advances down stream to the tape heads. During this move: (1) the minor flaps are closed, (2) the major flaps plow up and down, and (3) the case is closed and tape is applied. The fully loaded case then discharges from the machine.