



Distributed by  
**DARTRONICS, INC.**  
PACKAGING AUTOMATION SPECIALISTS

ROBOTIC PACKAGING

# EnCompass® RCP-15

## Robotic Case/Carton Packer

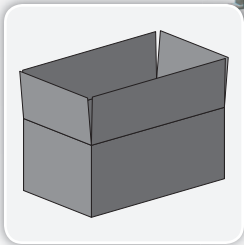

where products meet packaging®

Designed to provide maximum flexibility, performance and reliability in an compact footprint, the ADCO EnCompass® RCP-15 robotic case packer is ideal for the most demanding and space conscious production environments. The EnCompass® RCP-15 robotic case packer features end-of-arm tool designs that are based on ADCO's decades of complex product handling experience and can be configured to handle many types of case packing applications at rates up to 15 cases per minute when configured with a single packing robot. Additional packing robots may be used to increase the speed in certain applications. ADCO's EnCompass® RCP-15 robotic case packer provides packagers with unparalleled speed, adaptability and investment protection. The EnCompass® RCP-15 features stainless steel construction and is available in either standard or food grade configurations.

### Benefits

- Stainless steel construction improves cleanability and eliminates corrosion
- Modular design and use of robots make it easy to change to different package styles
- Small footprint saves space and eases integration into space constrained areas
- Simple, robotic design with few moving parts allows for easy, low-cost maintenance
- Precision robotic motion ensures gentle product handling and quality output
- Fast, easy tool change reduces downtime and improves productivity

# EnCompass® RCP-15 - Robotic Case/Carton Packer

## Product Features

- Capable of speeds up to 15 cases per minute, depending on the application
- Able to erect, pack and seal a wide variety of carton and case styles
- Compact 14' x 7' welded heavy duty frame
- 6' "inset mount" powered case magazine
- Sanitary design with easy access for changeover and cleanup
- Multiple infeed options including flat belt and servo-driven racetrack designs
- Allen-Bradley® PLC control package with touchscreen HMI interface
- Category 3 safety system with fully interlocked barrier guard package
- Many options available upon request

## Typical Applications

- Retail Ready
- Snack foods
- Baked goods in trays
- Flow-wrapped products
- Frozen meats
- Dairy
- Personal care
- Cosmetics

## Utilities

### Electrical

230/460

VAC, 3-Phase with ground (PE), 60 Hz

### Air Consumption

Consult Factory

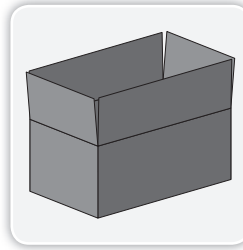

## PLAN VIEW

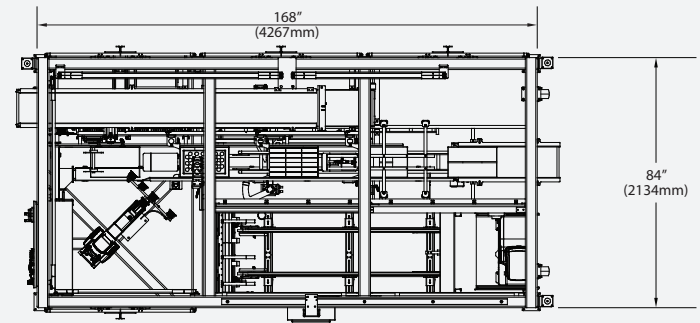

## SIDE ELEVATION

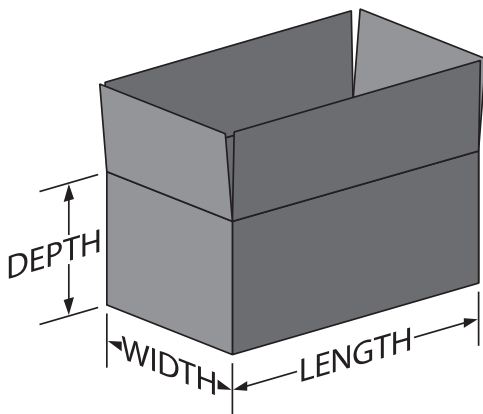
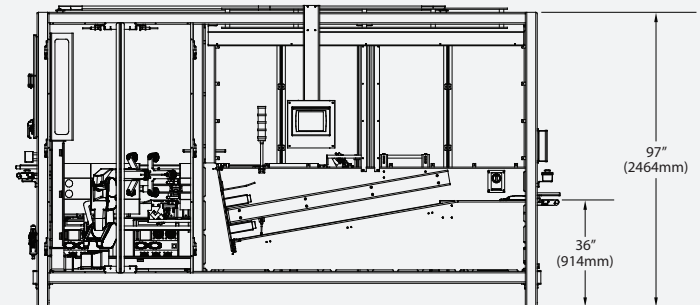

## CASE SIZE RANGE

Dimensions	(in)		(mm)	
	Min	Max	Min	Max
Length of Opening	Varies by Application			
Width of Opening	Varies by Application			
Case Depth	Varies by Application			

Not all minimums and maximums apply.  
Special modifications are available to extend the size range.



For more information about this machine, scan the QR code above with your mobile device