

# VHL

## Vertical Hand Load Cartoner



**DARTRONICS, INC.**  
PACKAGING AUTOMATION SPECIALISTS  
WE MEET YOU AT THE POINT OF TECHNOLOGY

**ADCO**  
where products meet packaging

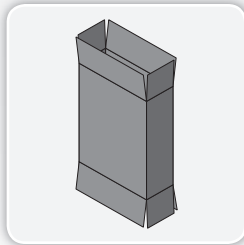
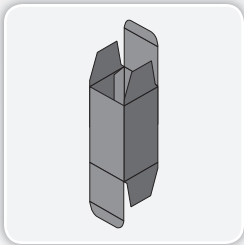
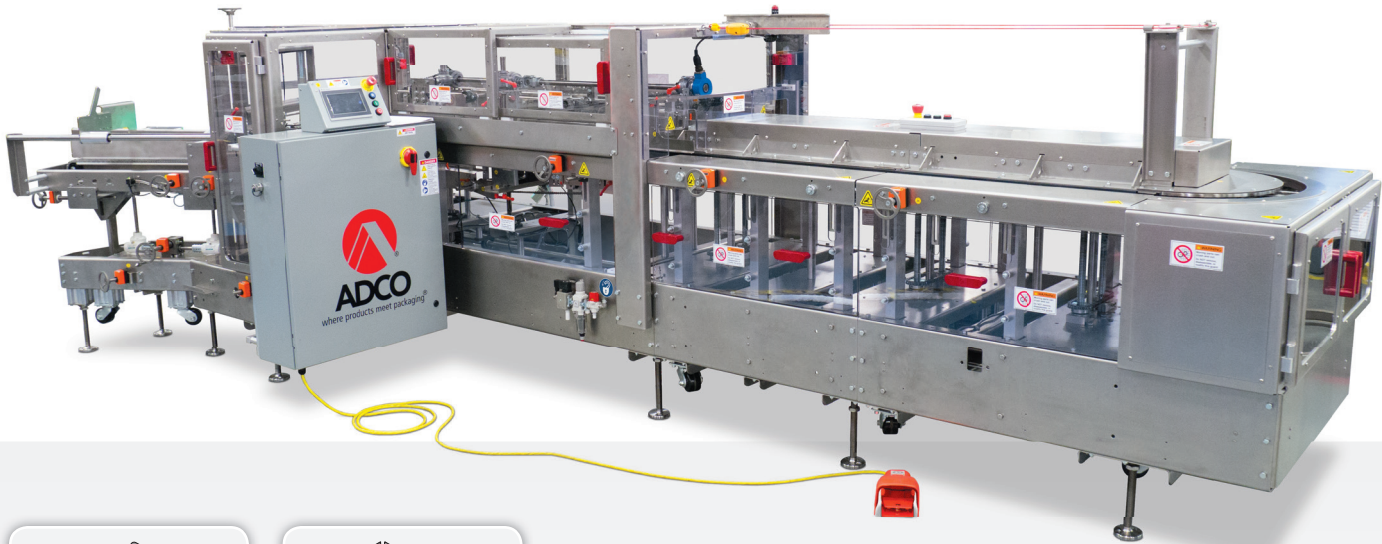

where products meet packaging®

Capable of cycling at rates up to 125 cartons per minute, the ADCO model VHL Vertical Hand Load Cartoner is the answer for difficult to load or loose-fill products that must be loaded on a vertical axis. The VHL is a continuous motion machine that erects and closes the bottom of the carton before indexing the cartons into a standard U-shaped hand-load area, which offers an ample 3-ft of loading space on both sides of the machine. After the product is loaded by the operators, the top of the carton is automatically closed and the sealed carton is then discharged from the machine. The VHL features fully interlocked barrier guarding and main drive overload circuit to protect operators. Its ergonomic load area accommodates seated or standing operator positions. Like all ADCO machines, the VHL is constructed out of stainless steel and is available in both, standard and wash-down configurations.

### Benefits

- Stainless steel construction provides maximum strength as well as improved sanitation over traditional designs
- Fast, easy changeover with scales and pointers and available digital counters maximizes reliability and increases productivity
- Intuitive and modern interface enhances operator experience and improves overall equipment effectiveness (OEE)
- Advanced guard design keeps operators safe and maximizes maintenance access

# VHL - Vertical Hand Load Cartoner

## Product Features

- Heavy duty stainless steel construction
- Line shaft drive with overload protection (available servo options)
- 2-head rotary feeder (available 3-head and 4-head options)
- Compact 14' frame with leveling feet and casters
- High capacity, easy to load carton magazine
- U-shaped product load area featuring a combined six feet (6') of loading space
- Fast and easy changeover with scales and pointers (available digital counters)
- Modern and intuitive operator interface
- Allen Bradley® PLC control package
- Category 3 safety system with fully interlocked barrier guard package
- Many other available options

## Typical Applications

- Refrigerated & Frozen Foods
- Bakery & Snack Foods
- Confections
- Nutritional Products
- Personal Care
- Pharmaceutical
- Soaps and Detergents

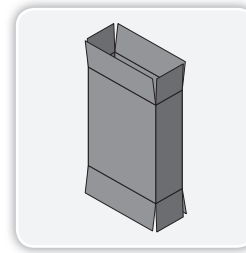
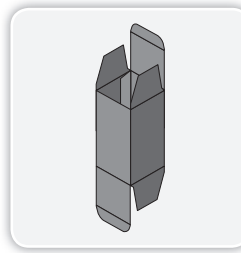
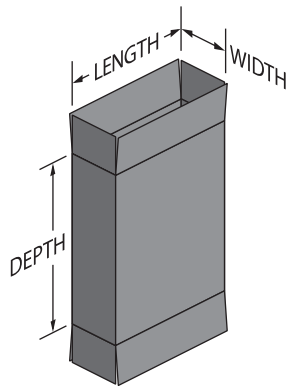

## PLAN VIEW

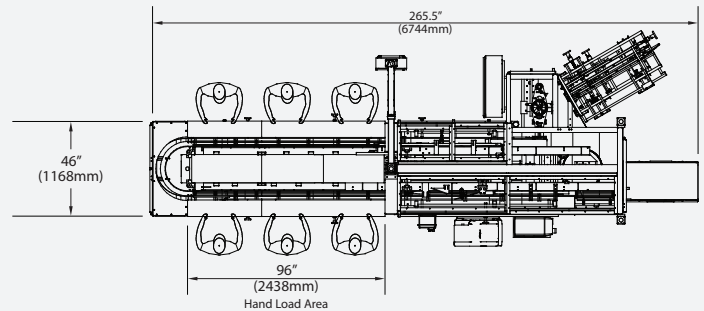

## SIDE ELEVATION

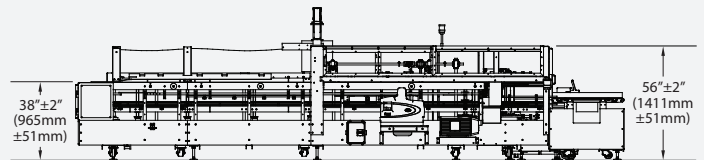

## Feeder Options:

- Three (3) and four (4) head rotary carton feeders
- Extended carton magazines
- Extended hand-load areas
- Deboss, ink, or laser coders
- And much more

## Closing options:

- Pressurized hot melt glue
- Tablock tuck, and gable top closing plows
- Scale fill, volumetric fill, and robotic automatic product loading options are also available.

## Utilities

### Electrical

230/460 VAC, 3-Phase with ground (PE), 60 Hz

### Air Consumption

8-9 CFM @ 90 PSI (Venturi)

2-3 CFM @ 90 PSI (Pump)

## CARTON SIZE RANGE

Dimensions	(in)		(mm)	
	Min	Max	Min	Max
Length of Opening	2	9.5	50	240
Width of Opening	.75	3	20	75
Case Depth	4	10	100	255

Not all minimums and maximums apply. Special modifications are available to extend the size range.

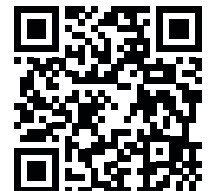

For more information about this machine, scan the QR code above with your mobile device