

CARTONING MACHINERY

SLC

High-Speed Inline Carton Closer



DARTRONICS, INC.
PACKAGING AUTOMATION SPECIALISTS

ADCO
where products meet packaging

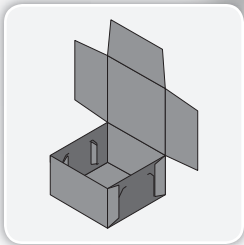

where products meet packaging®

Looking for a compact, high speed inline tri-seal carton closing solution? If so, look no further than the ADCO model SLC high-speed inline carton closer. Designed to handle wide variety of carton shapes and sizes at speeds up to 200 cartons per minute, the versatile SLC gets the job done, fast! Featuring a variable speed drive system, precision servo-controlled turning chains and no-tool changeover, the SLC packs a lot of features into its small frame. Plus, with its overhead chain and flexible gripper design handling bulging and oversize cartons is a breeze. This reliable and simple to operate carton closer is ideal for the most demanding and cost conscious production environments. Like all ADCO machines, the SLC is constructed in stainless steel and is available in standard or wash-down configurations.

Benefits

- Stainless steel construction improves cleanability and eliminates corrosion
- Positive, continuous motion lugged carton transfer maximizes control and reliability
- Overhead chain and flexible gripper design improves oversize carton handling
- Fast and easy “no-tool” changeover improves productivity and reduces downtime
- Large carton size and style range with protects your investment as products change
- Advanced guard design keeps operators safe and maximizes maintenance access

SLC - High-Speed Inline Carton Closer

Product Features

- Stainless steel construction
- 90 degree carton turn section with on-demand servo-controlled turning chains
- Cover right or cover left orientation
- No-tool changeover with digital readouts
- Variable speed drive system
- Accepts cartons randomly or back-to-back
- Compact frame with leveling feet and casters
- Nordson® ProBlue hot melt glue system
- Allen-Bradley® PLC control package with touchscreen HMI
- Category 3 safety system with fully interlocked barrier guard package
- Many options available upon request

Typical Applications

- Flow-wrapped products
- Frozen foods
- Ready meals
- Dairy products
- Baked goods

Utilities

Electrical

230/460 VAC, 3-Phase with ground (PE), 60 Hz

Air Consumption

10 CFM @ 70 PSI

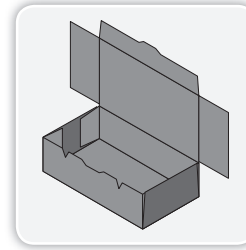
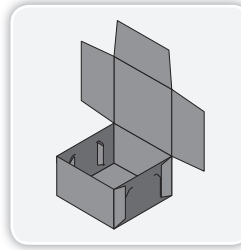
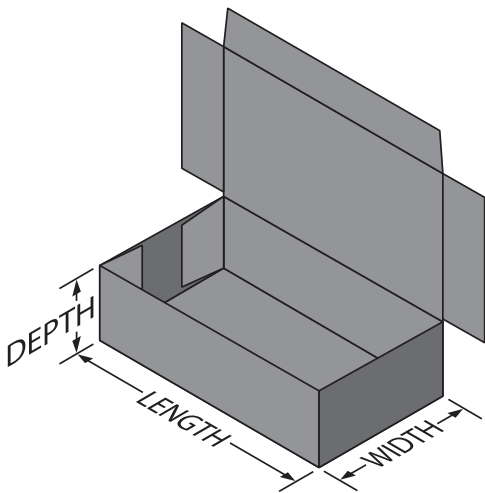

PLAN VIEW

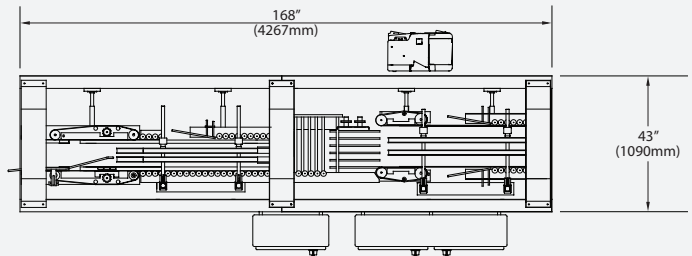

SIDE ELEVATION

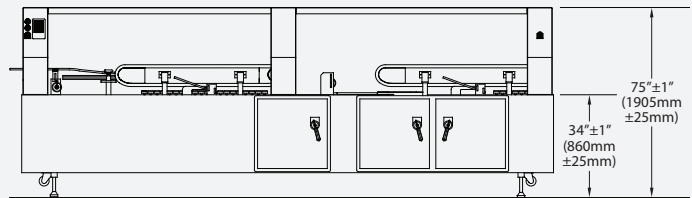

CARTON SIZE RANGE

Dimensions	(in)		(mm)	
	Min	Max	Min	Max
Length of Opening	4	11.75	100	300
Width of Opening	3	11.75	75	300
Case Depth	1	5	25	125

Not all minimums and maximums apply.
Special modifications are available to extend the size range.



For more information about this machine, scan the QR code above with your mobile device