



ORION FLEX LPD & FLEX HPD TURNTABLE PALLET WRAPPING SYSTEMS



Cost effective, rugged & reliable.

The Flex LPD & HPD are rugged and reliable semi-automatic stretch wrapping machines with all the features you need to quickly, efficiently, and economically wrap pallet loads.

Built for the most demanding industrial environments, the Flex LPD & HPD feature durable steel framework, AC motors, a belt-driven carriage lift and heavy-duty turntable support system, plus our unique Revo-Logic technology with photo-eye sensors improves the precision application of programmed wraps for maximizing load containment and film yield.

Starting in 2020 the Flex LPD & Flex HPD will come standard with the S-Carriage InstaThread film delivery system with a standard 260% pre-stretch and quick and easy loading.

LPD SPECIFIC FEATURES:

- 63" diameter turntable for loads up to 55" x 55"
- DuraGlide support rollers for quiet, reliable operation
- Load with a pallet jack, electric walkie, or forklift
- Full surround deck for turntable protection

GENERAL FEATURES:

- 7" IntelVue color, HD touch screen HMI
- 15 RPM variable speed w. "soft start"
- Revo-Logic technology for precise film application with maximum load containment and film yield
- 5,000 lb. Maximum load weight capacity
- Max load height 80" - standard, 110" - optional
- Film saving 260% powered film pre-stretch
- Automatic force to load for even film tension
- Forklift portable from front or rear
- Premium efficiency AC motors

HPD SPECIFIC FEATURES:

- 48" x 48" turntable for loads up to 55" x 55"
- Turntable with heavy-duty ring bearings
- Octagonal turntable for easy forklift loading

TYPICAL PRODUCT SPECIFICATIONS

Product Type	Turntable semi-automatic stretch wrapping machines
Speed	15 RPM

Display	7" color IntelVue HMI
Frame	Heavy-duty welded tubular steel
Electrical Requirements	115/1/60, 20 Amp electrical service (Not suitable for GFCI)

MACHINE DRAWINGS

Flex LPD - Dimensions - Inches

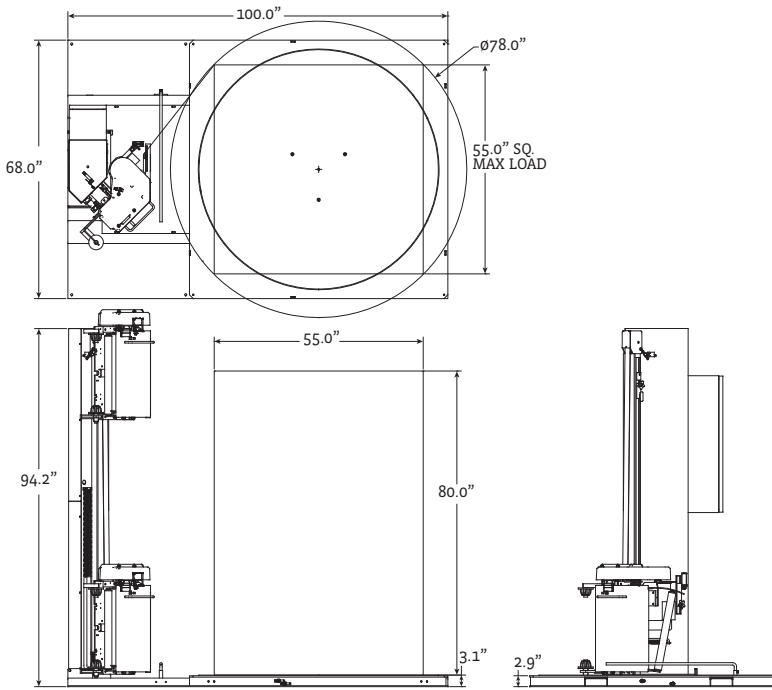

Flex HPD - Dimensions - Inches

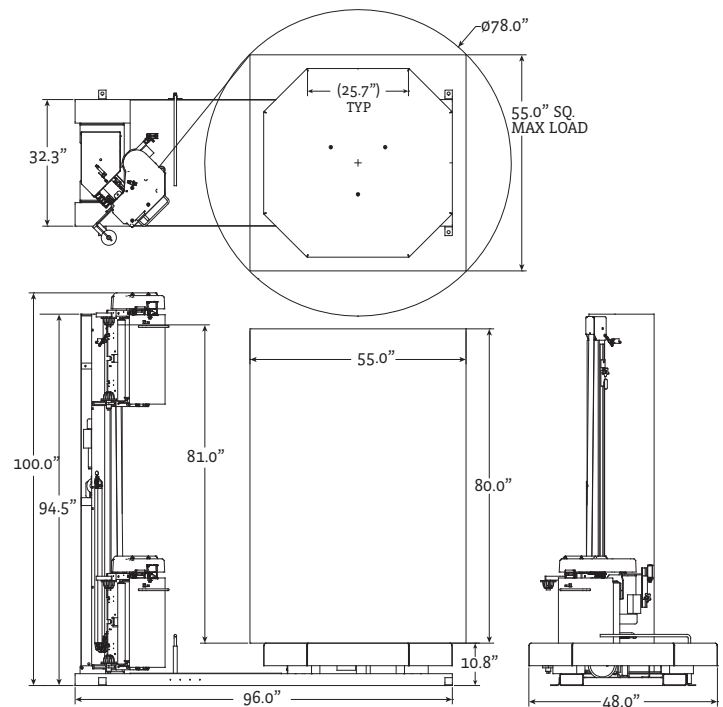

STANDARD FEATURES

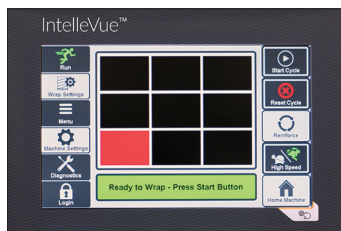

7" IntelVue HMI

User-friendly, password protected touch screen controls with up to 9 different wrap recipes.



Film Carriage Pre-stretch

The S-Carriage InstaThread Film Delivery System elongates film at a standard rate of 260%, providing the most secure loads at the lowest cost. Plus, film loading is fast, safe and easy.

OPTIONS

- Integrated scale
- Extended mast - 110"
- Extended base for oversized loads
- 1 HP drive upgrade - 6,000 lb. capacity
- Insta-Cut Automatic Film Web Severance
- Special Load Height Photocell for dark/ opaque loads
- 30" film carriage
- Dual turntables