

CARTONING MACHINERY

ConCENTRiX[®] SDBC

Horizontal End Load Cartoner



DARTRONICS, INC.
PACKAGING AUTOMATION SPECIALISTS

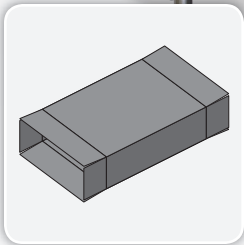

where products meet packaging[®]

The ADCO ConCENTRiX[®] SDBC Horizontal End Load Cartoner is sure to please even the most discerning packaging machinery buyer. Our designers have reimagined everything to bring you a cartoner like none other; highly sanitary, fast, efficient, reliable and best of all, affordable. Featuring centerline design with laser-etched scales, the ConCENTRiX[®] can be configured to erect, load and seal a wide range of carton sizes and styles at speeds up to 400 cartons per minute, making it ideal for the most demanding production environments. Also standard on the ConCENTRiX[®], is ADCO's fresh and intuitive InterACT[®] HMI. Available in several versions and with touchscreen interfaces up to 17" in size, InterACT[®] provides incomparable machine control, troubleshooting and performance reporting capability. The ConCENTRiX[®] comes equipped with the latest in servo-control with available push button automated changeover technology and much more. Like all ADCO machines, the ConCENTRiX[®] is constructed in stainless steel and is available in both, standard and wash-down configurations.

Benefits

- Sanitary stainless steel design maximizes cleanability and machine access
- Centerline design with laser etched scales and pointers reduces changeover time and enhances repeatability
- Flexible and adaptable design protects your investment as products change
- Orbital carton feeder with pre-break ensures smooth, efficient operation
- Easy to load magazine reduces operator fatigue and increases run time
- Advanced guard design keeps operators safe and maximizes maintenance access

ConCENTRIX® SDBC - Horizontal End Load Cartoner

Product Features

- Stainless steel construction
- Sanitary frame design
- Orbital carton feeder with pre-break
- Easy to load, high capacity magazine
- Product infeed conveyor with adjustable buckets
- Capable of erecting, loading and sealing either tuck-lock style or glued cartons
- Nordson® ProBlue hot melt glue system (when glue is specified)
- Allen-Bradley® PLC control system available with ADCO InterACT™ color touchscreen HMI
- PackML Programming
- Category 3 safety system with a fully interlocked barrier guard package
- Many options available upon request

Typical Applications

- Frozen Pizza
- Bag-in-Box
- Ready Meals
- Flow-wrapped Products
- Frozen Entrees
- Baked Goods
- Biscuits, Cookies & Crackers

Utilities

Electrical

230/460 VAC, 3-Phase with ground (PE), 60/50 hz

Air Consumption

2-3 CFM @ 80-PSI

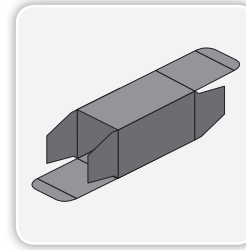
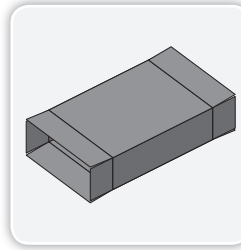

PLAN VIEW

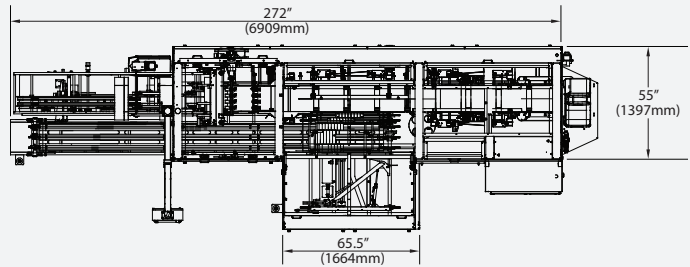

SIDE ELEVATION

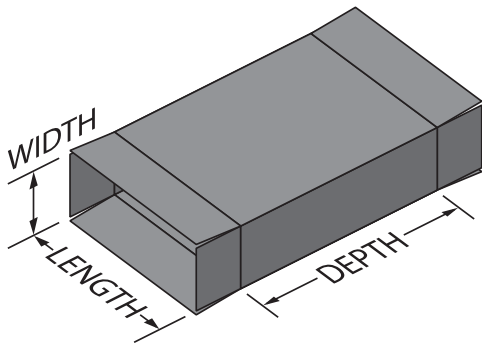
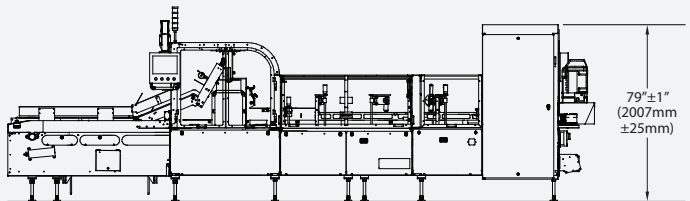

CASE SIZE RANGE

Dimensions	(in)		(mm)	
	Min	Max	Min	Max
Length of Opening	1.5	12.5*	40	320*
Width of Opening	.75	4	20	100
Case Depth	4.5	13	100	330

*With 15 inch carton flight centers
Not all minimums and maximums apply.
Special modifications are available to extend the size range.



For more information about this machine, scan the QR code above with your mobile device