

CARTONING MACHINERY

Compact 4

Vertical End Load Cartoner



DARTRONICS, INC.
PACKAGING AUTOMATION SPECIALISTS
11 811 80 11 8 11 81111 11 11 8000 0011

ADCO
where products meet packaging

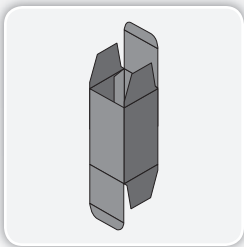

where products meet packaging®

Featuring the patented “Stella” 8-pocket quick size adjust starwheel, the ADCO Compact 4 was designed to form, load and seal small to medium size vertical end load cartons. The patented design can be configured with fully automatic product and leaflet loading options as well. With its space-saving footprint and flexible design, the Compact 4 is ideal for pharmaceutical and cosmetic packagers. This simple to operate and ergonomically designed machine includes two standard hand load stations coupled with lights curtains and product sensors for safe, automatic machine cycling speeds up to 40 cartons per minute. Like all ADCO machines, the Compact 4 is constructed in stainless steel and is available in standard or wash-down configurations.

Benefits

- Stainless steel construction improves cleanability and eliminates corrosion
- Patented “stella” 8-pocket quick adjust starwheel maximizes productivity and uptime
- Load area light curtains and product sensors ensure safe, automatic machine cycling
- Ergonomically designed product load areas minimize fatigue and maximize productivity
- Flexible design minimizes changeover time and protect investment as products change

Compact 4 - Vertical End Load Cartoner

Product Features

- Stainless steel construction
- Compact design with integrated stand and locking casters
- Two ergonomically designed product load area
- Quick adjust levers and scales on all adjustments
- Configurable with fully automatic product and leaflet loading options
- Allen-Bradley® PLC control package with teach box for machine tuning
- Capable of erecting and sealing tablock style or glued cartons
- Nordson® ProBlue hot melt glue system (when glue is specified)
- Advance guarding with light curtains and product sensors
- Many options available upon request

Typical Applications

- Pharmaceutical products
- Cosmetics
- Household products
- Novelties
- Candy and confectionery

Utilities

Electrical

230/460 VAC, 3-Phase with ground (PE), 60 Hz

Air Consumption

2-3 CFM @ 65-70 PSI

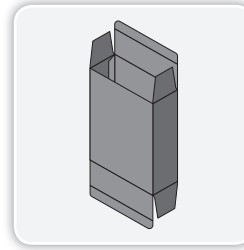
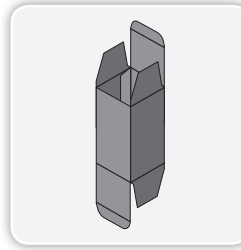
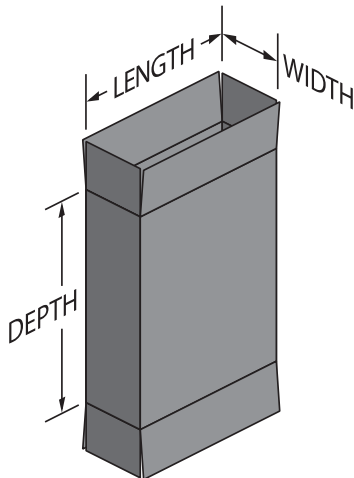

PLAN VIEW

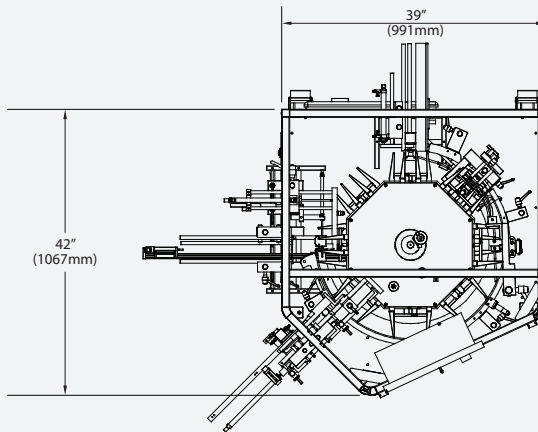

SIDE ELEVATION

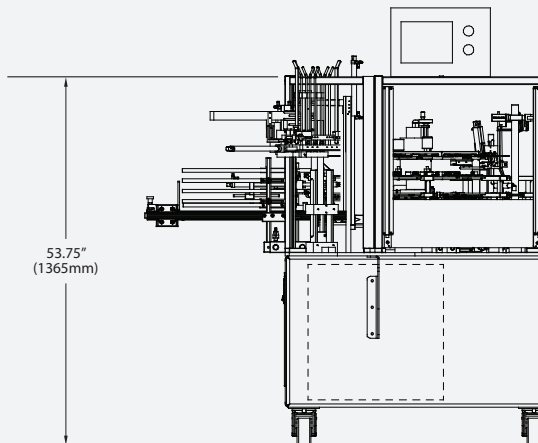

CARTON SIZE RANGE

| Dimensions | (in) | | (mm) | |
|-------------------|------|------|------|-----|
| | Min | Max | Min | Max |
| Length of Opening | 1 | 4.72 | 25 | 120 |
| Width of Opening | .71 | 4.54 | 18 | 90 |
| Case Depth | 2.36 | 7.09 | 60 | 180 |

Not all minimums and maximums apply.
Special modifications are available to extend the size range.

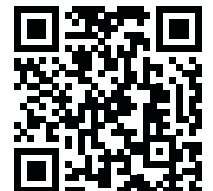

For more information about this machine, scan the QR code above with your mobile device