

# Colamark

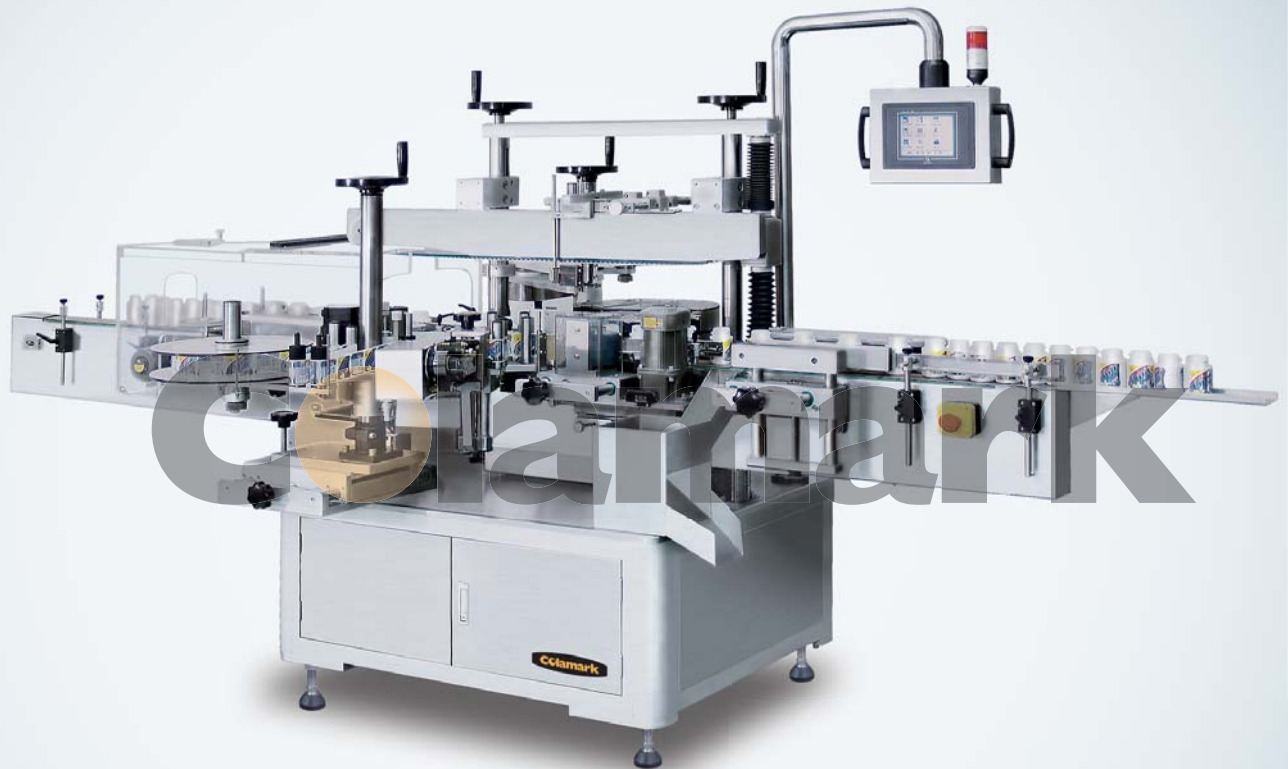

## A923 Front/Back and Orientation Wrap-around Labeling System

Suitable for three kinds of bottle shape (round, square, flat etc.), makes two labels and orientation labeling requirement possible. Speed up to 140 bottles per minute for orientation labeling; two labels and common round bottle labeling speed up to 200 bottles per minute.



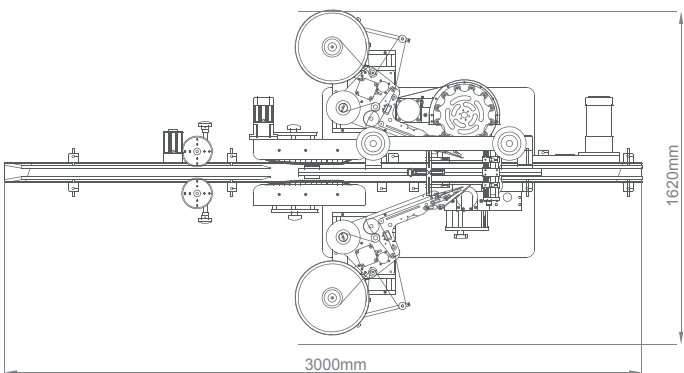
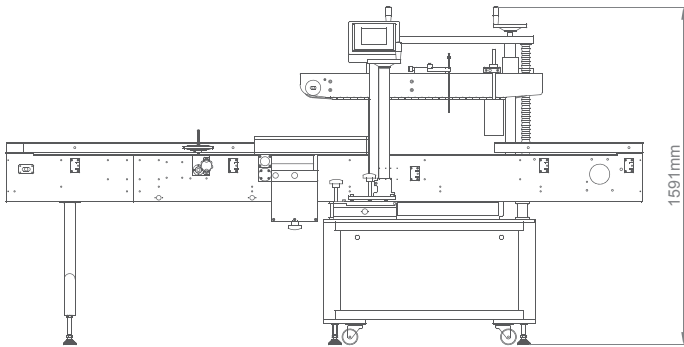

## Features

- ▶ A dual-function labeler for wide range of applications:
- ▶ Simple adjustment to swap between side labeling mode and orientation wrap-around labeling mode.
- ▶ One labeler to handle three different shapes of bottles (rectangular, oval, round) with large size ranges, and also achieves orientation in wrap-around labeling.
- ▶ Servo motor driven registered wrap-around mechanism which is in the form of a roller wheel to effectively ensure accurate registration.
- ▶ Design features to ensure precise and smooth labeling on oval or rectangular bottles:
  - An alignment device composed of a pair of side chains to ensure symmetrical alignment of bottles along the center line.
  - A top conveyor belt at synchronized speed with the main conveyor to hold the bottles in place to maintain bottle alignment and stability throughout the labeling process.
- ▶ Optional special label sensor for detection of film transparent labels.
- ▶ 50 sets of labeling parameters memory allows easy changeover between different labeling jobs by switching the pre-defined parameters set.
- ▶ Intelligent label quantity management, warning messages and optional visual inspection devices.

## Machine Model

## A923

Container Sizes	Oval/Rectangular : Width(across the direction of movement) 30-90mm, Height<300mm Round: Diameter 22-100mm
Labeling Speed	Side Labeling: 60-200 bpm Orientation Wrap-Around Labeling: 40-140 bpm (depends on bottles & label sizes)
Labeling Precision	± 1.0mm (other than errors from bottles or labels)
Machine Demensions	(L)3000 mm × (W)1620 mm × (H)1591 mm
Power Consumption	220VAC±5% 50Hz 1.68kW

( Custom engineered solutions are available to cater for customer's special needs. )

For continuous improvement on design and product innovations, all specification data are subject to change without prior notice

## Colamark (Guangzhou) Labeling Equipment Limited

19 Jin Xiu Road, GETDD, Guangzhou, China

Tel: +86 20 8221 6718 Fax: +86 20 8221 5799 PC:510730

## Colamark Technologies Limited

820 Topsail Plaza,11 On Sum Street,Shatin, Hong Kong  
Tel: +852 2634 8011 Fax: +852 8161 3311 Email: info@colamark.com Web: www.colamark.com

|HongKong | Guangzhou | Kunming Chengdu | Wuhan | Chongqing | Xian | Shanghai | Qingdao | Beijing | Shenyang | Harbin|



150 William Street Perth Amboy, NJ 08861  
1-800-298-8936  
Phone: 732-324-0800  
Fax: 732-324-4488  
Email: sales@dartronics.com  
www.dartronics.com