

# Colamark



## A201 Horizontal Vial Labeling System

**HIGH SPEED** An ideal high speed labeling solution (up to 300 bottles/min.) for vials and small round bottles for the pharmaceutical industry.

**TRAY INSERTION** Optional automatic tray insertion after labeling to build an integrated process of feeding, coding, labeling and packaging of vials.

**PRECISION** Horizontal conveying of bottles is handled by roller conveyor. No worry about the small round bottles standing upright stability. Alignment of bottle is based on the bottle body that enhances label alignment precision.

## Features

- ▶ Horizontal feeding using roller conveyor and wrap around of bottles enable handling thin bottles that cannot stand upright stably. Horizontal wrapping uses the bottle body for alignment ensures label alignment accuracy.
- ▶ Various inspection functions available as options for missed label, missed code or wrong code etc. by machine vision devices or photo-electric devices. Failed bottles upon inspection will be rejected accurately right after labeling.
- ▶ New generation bottle-to-tray inserting device to put the bottles into carton inner trays after the labeling process at a matching speed. (Optional)
  - Accurately controlled tray movement to allow smooth placement of bottles into the tray.
  - Simple adjustments and change parts for different sizes of bottles and trays.
  - Trays can be loaded manually on to the tray conveyor easily.
  - An optional automatic tray loader is available.
  - Tray insertion is completely synchronized with the labeling action with a bottle buffer. Labeling machine will slow down at high buffer and trays will stop at low buffer.
- ▶ Optional hot-stamping coder, thermal transfer over-printer, or inkjet coder can be integrated into the system seamlessly. Device status and alarm signals are reflected in the system.

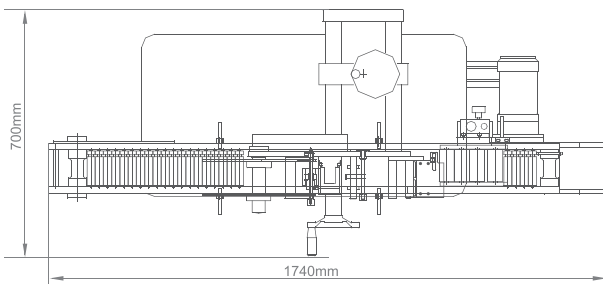
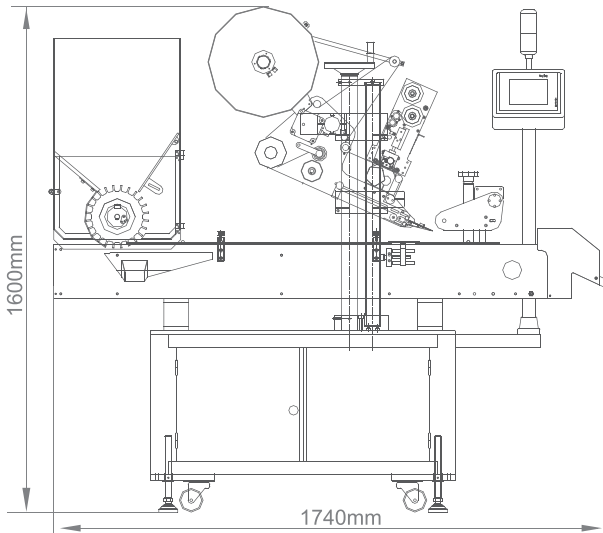

### Machine Model

### A201

Bottle Size	Diameter: $\Phi$ 10-22mm, $\Phi$ 18-30mm
Labeling Speed	200-300 bottles/min (depends on bottles & label sizes)
Labeling Precision	$\pm$ 0.5mm (other than errors from bottles or labels)
Air	0.4–0.6Mp (required by hot-stamping coder)
Power Consumption	220VAC $\pm$ 5% 50Hz 1.0kW
Machine Dimensions	(L)1740mm x (W)700mm x (H)1600mm

( Custom engineered solutions are available to cater for customer's special needs. )

由于产品升级和设计上的不断更新, 本公司保留对本单张的产品规格作出修改的权利, 而无需在事前另行公布



150 William Street Perth Amboy, NJ 08861  
1-800-298-8936  
Phone: 732-324-0800  
Fax: 732-324-4488  
Email: sales@dartronics.com  
www.dartronics.com

### 达尔嘉 ( 广州 ) 标识设备有限公司

电话: (020) 8221 6718

电邮: info@colamark.cn

广州 经济技术开发区 锦秀路19号

传真: (020) 8221 5799

网址: www.colamark.cn

技术热线: 400 810 9710

邮编: 510730

### Colamark Technologies Limited

820 Topsail Plaza, 11 On Sum Street, Shatin, Hong Kong

香港 • 广州 • 昆明 • 成都 • 武汉 • 重庆 • 西安 • 上海 • 青岛 • 北京 • 沈阳 • 哈尔滨