

Colamark

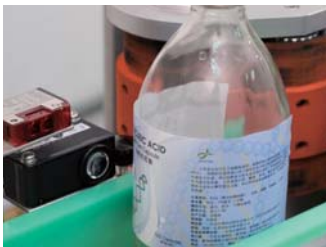

(The feeding turntable and collection tray shown are optional items)



Colamark A101 Vertical Round Labeling Machine

- ▶ The ideal and economical choice for the pharmaceutical, foods and beverages, and daily chemicals industries for automatic labeling on round containers that can stand upright stably.
- ▶ Servo motor driven labeling engine with PLC control to ensure high speed and precise labeling.
- ▶ Automatically detect the label size and bottle diameter and automatically determine the right parameters for fast change over of products.
- ▶ All stainless steel and aluminum profile construction for GMP compliance.
- ▶ Ready for inline connection easily. Optional feeding and collecting table for full stand alone use.

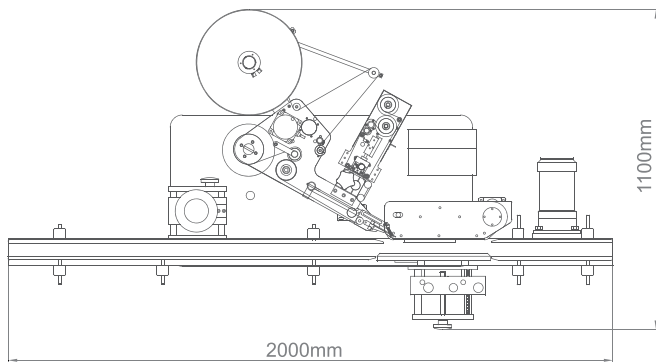
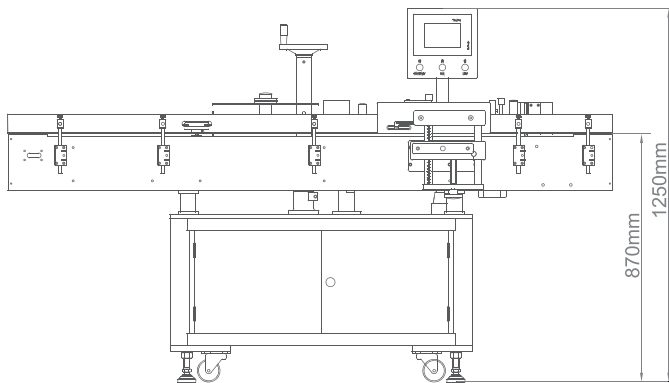

Features

- Intelligent control - automatically detects the label length and alarm for label end detection. Optional bottle diameter detection and auto set-up for the appropriate labeling parameters in the machine.
- Highly user friendly interactive touch-screen control makes operation convenient and straight forward. Also offers rich of on-screen help functions and error alarms.
- 50 sets of labeling parameter memory allows easy changeover between different labeling jobs.
- Motorized separator to ensure correct bottle spacing.
- The labeler can be integrated easily into an existing production line for in-line operation. Alternatively, optional feeding (collecting) tables for bottles are available for fully stand-alone operation.
- Optional hot-stamping coder, thermal transfer printer, or inkjet coder for date-coding on the labels.
- Barcode reader - optional on-line barcode reader to capture bar code data on labels. Optional rejection device is available for labels with unreadable barcodes.

Machine Model

A101

Bottle Size	Diameter: Φ 20-90mm Height: 30-160mm
Labeling Speed	100-250 bottles/min (depends on bottles & label sizes)
Labeling Precision	\pm 1.0mm (other than errors from bottles or labels)
Machine Dimensions	(L)2,000mm \times (W)1,100mm \times (H)1,250 mm
Power Consumption	220VAC \pm 5% 50Hz 1kW

(Custom engineered solutions are available to cater for customer's special needs.)

For continuous improvement on design and product innovations, all specification data are subject to change without prior notice

Colamark (Guangzhou) Labeling Equipment Limited

19 Jin Xiu Road, GETDD, Guangzhou, China

Tel: +86 20 8221 6718 Fax: +86 20 8221 5799 PC:510730

Colamark Technologies Limited

820 Topsail Plaza,11 On Sum Street,Shatin, Hong Kong
Tel: +852 2634 8011 Fax: +852 8161 3311 Email: info@colamark.com Web: www.colamark.com

|HongKong | Guangzhou | Kunming Chengdu | Wuhan | Chongqing | Xian | Shanghai | Qingdao | Beijing | Shenyang | Harbin|



150 William Street Perth Amboy, NJ 08861
1-800-298-8936
Phone: 732-324-0800
Fax: 732-324-4488
Email: sales@dartronics.com
www.dartronics.com