

CARTONING MACHINERY

ControlARC® CF600s/CF1200s Top Load Carton Former



where products meet packaging®

Featuring ADCO's innovative ControlARC® design, the CF-600s and CF-1200s top load tray formers were conceived from the ground up to deliver excellent performance and flexibility along with extraordinary ergonomics and reliability. ADCO's ControlARC® design allows these machines to be fitted with a low-level, easy to load magazine to help control worker fatigue and it also provides maximum control and flexibility when handling material variations. Delivering class-leading carton erecting performance at speeds up to 60 cycles per minute, these top load carton formers are a great choice for many applications including Retail Ready and Shelf Ready packaging. Fast changeover, simple operation and clean design make the CF family of tray formers ideal for the most demanding production environments. Like all ADCO machines, the CF-600s and the CF-1200s are constructed in stainless steel and are available in standard or wash-down configurations.

Benefits

- Stainless steel construction and sanitary design improves cleanability and eliminates corrosion
- ControlARC® design provides extraordinary ergonomics and maximizes control
- Fast, easy changeover reduces downtime and increases productivity
- Large carton size range and style range protects your investment as products change
- Easy integration to other ADCO top load machinery saves time and money
- Advanced guard design keeps operators safe and maximizes maintenance access

CF600s/CF1200s - Top Load Carton Former

Product Features

- Stainless steel construction
- ControlARC® shuttle carton feed system with pinch rollers
- Ergonomic, low-load carton magazine
- Multi-axis variable speed drive system
- Available with up to two (2) forming heads (CF-1200s)
- Compact frame with leveling feet and casters
- Unformed carton sensing system
- Capable of forming lock style or glued cartons and trays
- Nordson® ProBlue hot melt glue system with pattern control (when glue is specified)
- Allen-Bradley® PLC control package with touchscreen HMI interface
- Category 3 safety system with fully interlocked barrier guard package
- PackML programming
- Jog cord with pushbutton and water tight outlet
- Many options available upon request

Typical Applications

- Snack foods
- Baked goods in trays
- Flow-wrapped products
- Frozen meats
- Dairy
- Household products

Utilities

Electrical

230/460 VAC, 3-Phase with ground (PE), 60 Hz

Air Consumption

10 CFM @ 70 PSI

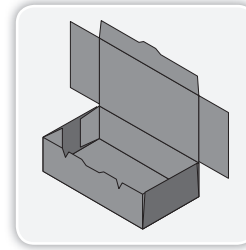
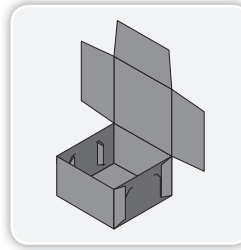

PLAN VIEW - CF600s

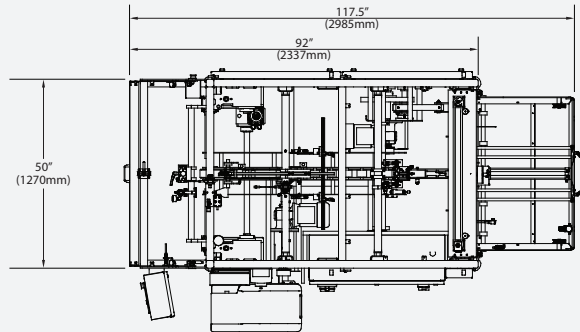

PLAN VIEW - CF1200s

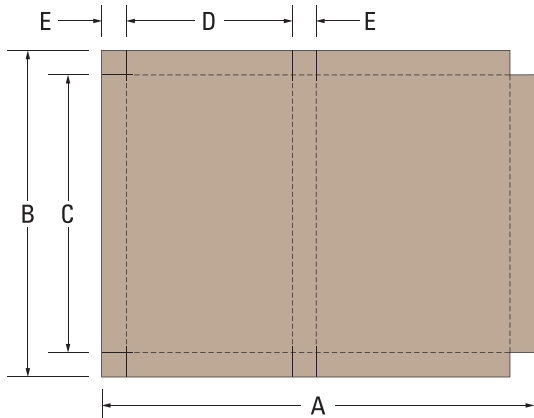
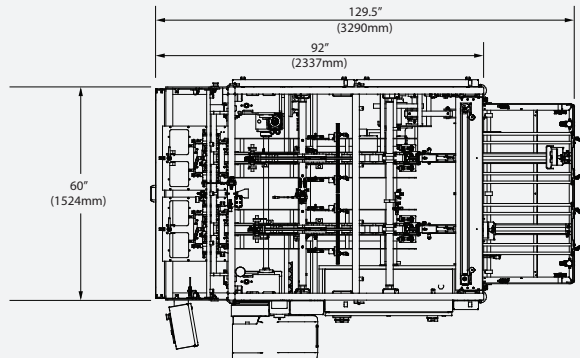

CARTON SIZE RANGE

Dimensions	(in)		(mm)	
	Min	Max	Min	Max
A	7.5	23	190	585
B	5	26	130	660
C	3	17	75	430
D	3	8	75	200
E	.75	4.5	19	115

Not all minimums and maximums apply. Special modifications are available to extend the size range.

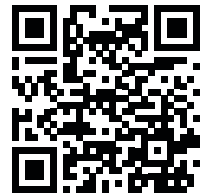

For more information about this machine, scan the QR code above with your mobile device