

15HCS

Horizontal Carton Sealer

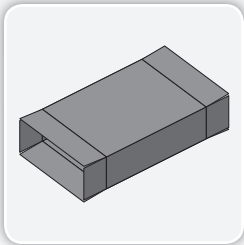

where products meet packaging®

Looking for an affordable horizontal carton sealing solution for your new product launch or short production run? If so, the ADCO 15HCS is just what you are looking for. This compact and easy to operate continuous motion machine is capable of sealing a wide range of carton sizes at speeds up to 50 cartons per minute. Simply place a pre-filled carton into the 15HCS from either side of the load area and it will take care of the rest; quick, easy and efficient. Designed with flexibility and portability in mind, the robust 15HCS horizontal carton sealer is ideal for the most demanding and cost conscious production environments. Like all ADCO machines, the 15HCS is constructed in stainless steel and is available in standard or wash-down configurations.

Benefits

- Stainless steel construction improves cleanability and eliminates corrosion
- Positive, continuous motion lugged carton transfer maximizes control and reliability
- Fast, easy changeover improves productivity and reduces downtime
- Large carton size range protects your investment as products change
- Pressurized glue system minimizes glue consumption and reduces clean up
- Advanced guard design keeps operators safe and maximizes maintenance access

15HCS - Horizontal Carton Sealer



DARTRONICS, INC.
PACKAGING AUTOMATION SPECIALISTS

150 William Street Perth Amboy, NJ 08861
1-800-298-8936
Phone: 732-324-0800
Fax: 732-324-4488
Email: sales@dartronics.com
www.dartronics.com

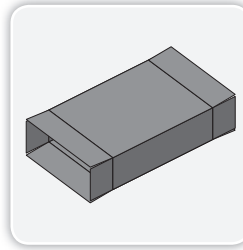

Product Features

- Stainless steel construction
- Continuous motion lugged carton transfer system
- Compact frame with leveling feet and casters
- Easy access drive system
- Quick Adjust
- Casters and leveling feet
- Nordson® ProBlue hot melt glue system
- Allen-Bradley® control package
- Fully interlocked barrier guard package
- Many options available upon request

Typical Applications

- Flow-wrapped products
- Baked goods
- Snack foods
- Frozen foods
- Consumer products
- Confectionery

Utilities

Electrical

230/460 VAC, 3-Phase with ground (PE), 60 Hz

Air Consumption

10 CFM @ 95 PSI

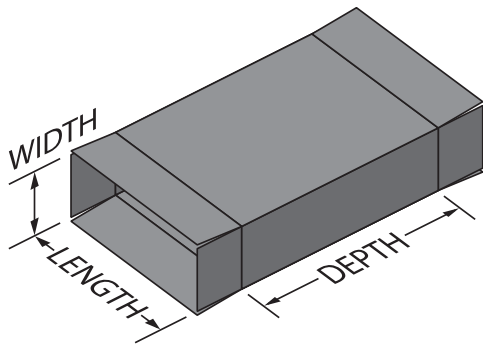

PLAN VIEW

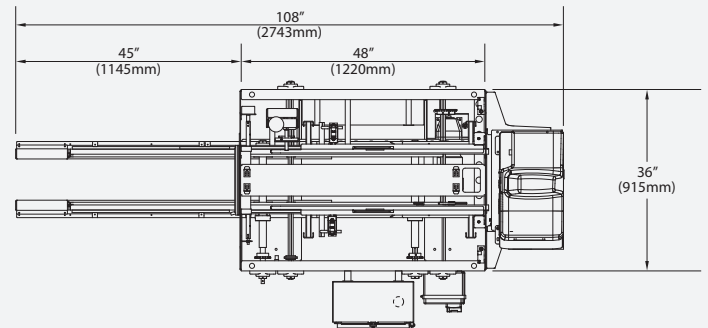

SIDE ELEVATION

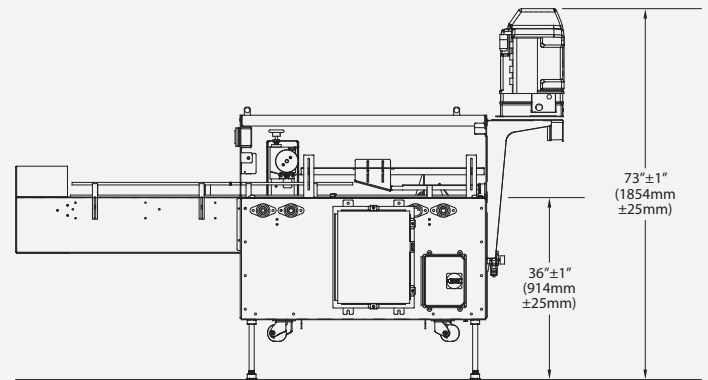

CARTON SIZE RANGE

Dimensions	(in)		(mm)	
	Min	Max	Min	Max
Length of Opening	2	12	12	305
Width of Opening	.75	4.5	20	115
Case Depth	3.5	12	90	305

Not all minimums and maximums apply.
Special modifications are available to extend the size range.

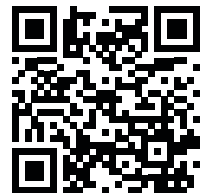

For more information about this machine, scan the QR code above with your mobile device

