

CARTONING MACHINERY

15DBC105

Horizontal End Load Cartoner



DARTRONICS, INC.
PACKAGING AUTOMATION SPECIALISTS

ADCO
where products meet packaging

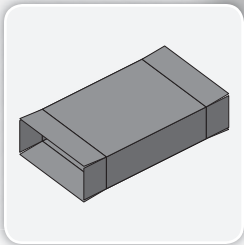

where products meet packaging[®]

ADCO's popular 15DBC105 cartoner has the flexibility, reliability and functionality that today's packager's need. Capable of erecting, loading and sealing a wide range of carton sizes and styles at speeds up to 125 cartons per minute, the value packed 15DBC105 is ideal for the most demanding and cost conscious production environments. Along with its continuous motion design, the 15DBC105 includes a fully automatic barrel cam product inserter with an adjustable overload sensor protected retract system. Smooth, efficient and reliable operation with minimal downtime and maintenance requirements, are just a few of the key attributes that have made the 15DBC105 a popular choice. With simple operation and excellent ergonomics the 15DBC105 really delivers. Like all ADCO machines the 15DBC105 is constructed in stainless steel and is available in standard or wash-down configurations.

Benefits

- Stainless steel construction improves cleanability and eliminates corrosion
- Two-head rotary carton feeder ensures smooth, efficient operation
- Fast, easy changeover with overhead screw adjustments and scales maximize productivity
- Large carton size range with oversizing options protects your investment as products change
- Adjustable infeed and transfer conveyor pockets provide flexibility
- Advanced guard design keeps operators safe and maximizes maintenance access

15DBC105 - Horizontal End Load Cartoner

Product Features

- Stainless steel construction
- Compact 16' frame with leveling feet and casters
- Barrel cam inserter with adjustable overload
- sensor-protected retract system
- No product/no carton, no carton/no load sensing
- 4' horizontal powered easy-to-load carton magazine
- 2-head rotary carton feeder
- 80" product infeed conveyor
- Capable of erecting, loading and sealing either tablock style or glued cartons
- Nordson® ProBlue hot melt glue system (when glue is specified)
- Allen-Bradley® control package
- Fully interlocked barrier guard package
- Many options available upon request

Typical Applications

- Frozen foods
- Snack Foods
- Flow-wrapped products
- Bag-in-box
- Baked goods
- Consumer products

Utilities

Electrical

230/460 VAC, 3-Phase with ground (PE), 60 Hz

Air Consumption

10 CFM @ 95 PSI

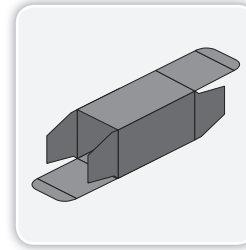
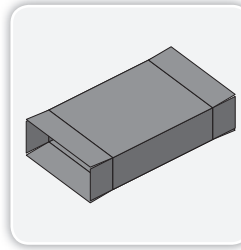

PLAN VIEW

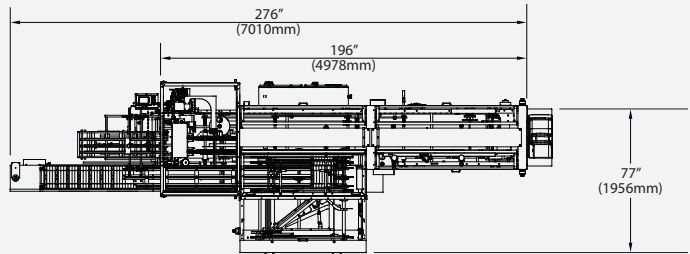

SIDE ELEVATION

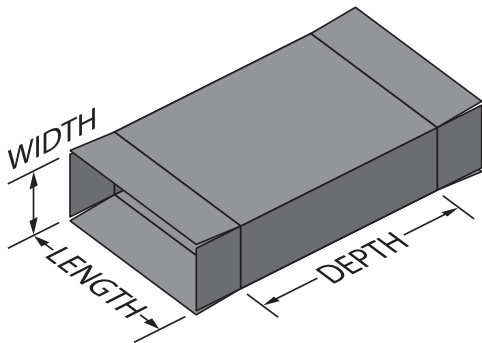
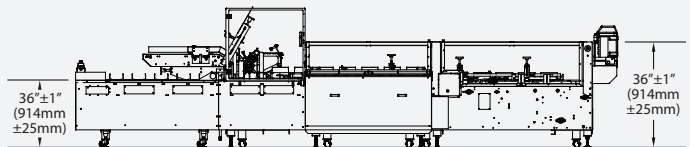

CARTON SIZE RANGE

Dimensions	(in)		(mm)	
	Min	Max	Min	Max
Length of Opening	1	9	25	225
Width of Opening	.75	4	20	100
Case Depth	4	12	100	305

Not all minimums and maximums apply.
Special modifications are available to extend the size range.

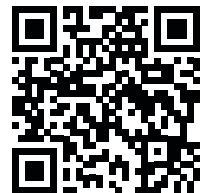

For more information about this machine, scan the QR code above with your mobile device